



156 Epping Road Exeter, NH 03833

800-261-7219

Stock Number: 488829 KW T880 LJ

2025 Kenworth T880 LJ

Details:

- 2024 NRC 40TB-28'
- Galvanized Deck and Subframe
- Lodar Remote
- 20k Winch
- Cummins X15
- 525HP
- Allison 4500RDS
- Full Chassis / Body spec attached

Price: \$331,143



Vehicle Summary

| | | | |
|-------------------------|-------------------------------------|-----------------------------------|----------------|
| | Unit | | Chassis |
| Model: | T880 Series Conventional | Fr Axle Load (lbs): | 20000 |
| Type: | FULL TRUCK | Rr Axle Load (lbs): | 40000 |
| Description 1: | T880 LJ | G.C.W. (lbs): | 80000 |
| Description 2: | | | |
| | Application | Road Conditions: | |
| Intended Serv.: | Heavy equipment transport. Vehicles | Class A (Highway) | 95 |
| | us | | |
| Commodity: | Heavy Machinery | Class B (Hwy/Mtn) | 5 |
| | | Class C (Off-Hwy) | 0 |
| | | Class D (Off-Road) | 0 |
| | Body | Maximum Grade: | 6 |
| Type: | Flatbed | Wheelbase (in): | 292 |
| Length (ft): | 24 | Overhang (in): | 65 |
| Height (ft): | 12 | Fr Axle to BOC (in): | 74 |
| Max Laden Weight (lbs): | 8000 | | |
| | | Cab to Axle (in): | 218 |
| | | Cab to EOF (in): | 283 |
| | Trailer | Overall Comb. Length (in): | 405.5 |
| No. of Trailer Axles: | 0 | | |
| Type: | | | |
| Length (ft): | 0 | Special Req. | |
| Height (ft): | 0 | U.S. Domestic Registry, 50-state. | |
| Kingpin Inset (in): | 0 | | |
| Corner Radius (in): | 0 | | |
| | Restrictions | | |
| Length (ft): | 40 | | |
| Width (in): | 102 | | |
| Height (ft): | 15 | | |

Approved by: _____

Date: _____

Note: All sales are F.O.B. designated plant of manufacture.

| Sales Code | Std/ Opt | Description | \$ List | Weight |
|-------------------------------|----------|------------------------------------------------------------------------------------------------------------------------------------------------------------------------------------------------------------------------------------------------------------------------------------------------------------------------------------------------------------------------------------------------------------------------------------------------------------------------------------------------------------------------------------------------------------------------------------------------------------------------------------------------------------------------------------------------------------------------------------------------------------------------------------------------------------------------------------------------------------------------------------------------------------------------------------------------------------------------------------------------------------------------------------------------------------------------------------------------------------------------------------------------------------------------------------------------------------------------------------------------------------------------------------------------------------------------------------------------------------------|---------|--------|
| Model | | | | |
| 0000810 | S | T880 Series Conventional | 234,126 | 15,549 |
| 0070060 | S | T880 | 0 | 0 |
| 0072000 | O | Chassis Operation Will Not Incl. Stationary application. Stationary operation is defined as running the engine under load while stationary at a substantial fraction of engine gross horsepower (60% or greater) for an extended period of time (longer than 5 - 10 minutes). | 0 | 0 |
| 0080055 | O | CARB Clean Idle Label - Cummins Engines | 106 | 0 |
| 0080310 | O | EPA Clean Idle Label - Cummins Engines | 107 | 0 |
| 0090000 | S | Non-Sleeper w/ Rear Axle Capacity less than 59K. | 0 | 0 |
| 0098429 | O | State of Registry: New Hampshire | 0 | 0 |
| Engine & Equipment | | | | |
| 0130359 | O | Cummins X15 525 525@1900 1850@1000, 2024 with Intebrake, Performance Series N09420 C333 0.....Reserve Speed Limit Offset (N09380 C334 0.....Maximum Cycle Distance (C334 N09360 C400 252...Reserve Speed Function Reset N09200 C399 120...Standard Maximum Speed Limit N09400 C401 10....Maximum Active Distance (C40 N09220 C402 0.....Expiration Distance (C402) N09540 C395 0.....Expiration Distance (C395) N09260 C121 65....Maximum Accelerator Pedal Ve N09440 C234 YES...Engine Protection Shutdown (N09460 C231 YES...Gear Down Protection (C231) N09580 C133 5.....Timer Setting (C133) N09680 C233 NO....Idle Shutdown Manual Overrul N09480 C132 1400..Max PTO Speed (C132) N09300 C128 65....Maximum Cruise Speed (C128) N09500 C239 YES...Cruise Control Auto Resume (N09520 C238 YES...Auto Engine Brake in Cruise N09240 C209 120...Hard Maximum Speed Limit (C2 N09780 C190 80....High Ambient Temperature Thr N09740 C188 40....Low Ambient Temperature Thre N09760 C189 60....Intermediate Ambient Tempera N09720 C382 YES...Enable Hot Ambient Automatic N09600 C396 YES...Enable Impending Shutdown Wa N09620 C397 60....Timer For Impending Shutdown N09640 C206 35....Engine Load Threshold (C206) N09560 C225 YES...Enable Idle Shutdown Park Br | 11,711 | 336 |
| 1000047 | O | CARB Emissions Warranty Engine | 0 | 0 |

| Sales Code | Std/ Opt | Description | \$ List | Weight |
|-------------------|-----------------|--------------------------------------------------------------------------------------------------------------------------------------------------------------------------------------------------------------------------------------------------------------------------------|----------------|---------------|
| 1000151 | S | PremierSpec | 0 | 0 |
| 1000244 | O | Gearing Analysis: Balance power/economy blend results. | 0 | 0 |
| 1000256 | O | Customer's Typical Operating Spd: 64 MPH | 0 | 0 |
| 1000524 | | RegistrationYear Year of Registration: 2024 | 0 | 0 |
| 1000684 | O | Effective VSL Setting NA | 0 | 0 |
| 1000858 | O | Engine Idle Shutdown Timer Disabled | 0 | 0 |
| 1000859 | O | Enable EIST Ambient Temp Override | 0 | 0 |
| 1000891 | O | Eff EIST NA Expiration Miles Use only with MX and Cummins engines | 0 | 0 |
| 1002080 | O | Air Compressor: Cummins 18.7 CFM, Naturally Aspirated for Cummins X15 engines | 211 | 0 |
| 1051200 | S | Air Cleaner: Composite Firewall Mounted PACCAR or Cummins Engines | 0 | 0 |
| 1105220 | O | Fan Hub: Horton 2-Speed for X15 | 24 | 0 |
| 1123555 | S | Cooling module: 1330 square inches. Includes aluminum radiator core, aluminum charge air cooler, translucent surge tank and washer bottle, silicone hoses, and extended life coolant. | 0 | 0 |
| 1160208 | O | Bug Screen: Between Hood & Grille | 128 | 2 |
| 1247251 | O | EXH: Single Can 2024 RH Under with Dual Side-of-Cab Tailpipes | 1,525 | -422 |
| 1290436 | O | Tailpipe: 7 in. dual 36 in. 45 degree curved. | 649 | 8 |
| 1292944 | O | Dual Lower Chrome Exhaust Elbow | 692 | 0 |
| 1321109 | O | Fuel Filter:PACCAR Standard Service Interval Fuel/Water Separator. 2017 and Later Emissions | 74 | 0 |
| 1321205 | S | Run Aid:Fuel Heat *For Fuel Filter | 0 | 0 |
| 1321305 | S | Start Aid:12V Heat *For Fuel Filter | 0 | 0 |
| 1500029 | O | Kenworth Fuel Cooler Required for Cummins engines with a single fuel tank. Required for PACCAR MX-13 engine with a single fuel tank and stationary use: High RPM, low vehicle speed, sustained for longer than 1 hour. Optional for all other applications. | 219 | 6 |
| 1504005 | O | Immersion Block Heater 120V 1500W W/ Plug Under Door on C500, T660, T800 & W900. | 150 | 2 |
| 1816260 | O | Alternator: PACCAR 160 amp, Brush Type | -6 | 0 |

| Sales Code | Std/ Opt | Description | \$ List | Weight |
|-----------------------------------|----------|----------------------------------------------------------------------------------------------------------------------------------------------------------------------------------------------------------------------------------------------------------------------------------------------------------------------------------------------|---------|--------|
| 1821210 | S | Batteries: 3 PACCAR GP31 Threaded Post (700-730) 2100-2190 CCA dual purpose. | 0 | 0 |
| 1836106 | O | Mitsubishi 105P55 12V Starter with Cummins and PX PACCAR 12 volt electrical system. W/ centralized power distribution incorporating plug-in style relays. Circuit protection for serviceability, 12-volt light system w/circuit protection circuits number & color coded. Only for Cummins or PX engines. | 0 | 0 |
| 1840065 | S | 12V Low Voltage Disconnect for Battery Protection | 0 | 0 |
| 1901017 | S | Remote PTO/Throttle, 12-Pin, Engine Bay Remote Control Provision | 0 | 0 |
| Transmission & Clutch | | | | |
| 2016627 | O | Transmission: Allison 4500RDS 6-speed, With PTO drive gear. No Retarder. 6th Generation controls. For vocational applications. Includes shift control, transmission oil temperature gauge, oil level sensor & heat exchanger. Transynd transmission fluid is standard on all Allison 1000, 2000, 3000 & 4000 series transmissions. | 26,055 | 478 |
| 2406803 | O | Driveline: 3 Dana SPL250XL W/ 2 Centerbearings Low maintenance offering from Spicer. On-highway 350K mi first service interval, 100K mi subsequent service interval on U-joint, splines lubed for life, quick disconnect end caps. | 2,339 | 187 |
| 2410018 | O | Torque Converter Included W/ Allison Transmission. | 0 | 0 |
| 2410151 | O | Pushbutton Control Center Console Mounted. Class 8 with Allison Transmission. | 0 | 0 |
| 2410204 | O | Allison Fuel Sense: Delete | 0 | 0 |
| 2410244 | O | J1939 Park Brake Auto Neutral | 0 | 0 |
| 2410310 | O | Allison Neutral at Stop | 0 | 0 |
| 2429358 | O | Rear Transmission Support Springs for transmission PTO applications are required to ensure that engine flywheel housings are not overloaded when transmission PTO's are installed. | 92 | 0 |
| 2429378 | O | Customer Installed Transmission PTO in the LH Mounted position (8 o'clock) for Allison 3000 & 4000 transmissions. | 0 | 0 |
| 2495023 | O | Two Steel Centerbearing Crossmembers Installed with Heavy-Duty Aluminum Gussets Replacing Standard. | 490 | 70 |
| Front Axle & Equipment | | | | |
| 2536002 | S | PACCAR FX-20 Front Axle rated at 20K 4" drop standard track | 0 | 0 |
| 2607002 | S | Front Brakes: 14,601-22K Bendix Air Disc Brakes. | 0 | 0 |
| 2690025 | O | Splined Rotor for Front Air Disc Brakes for Use with Iron Hubs. | -199 | 0 |
| 2690039 | S | Integral Knuckle for Air Disc Brake, for use on PACCAR FX Steer Axle | 0 | 0 |

| Sales Code | Std/ Opt | Description | \$ List | Weight |
|----------------------------------|-----------------|----------------------------------------------------------------------------------------------------------------------------------------------------------------------------------------------------------------------------|----------------|---------------|
| 2702020 | O | Front Hubs Iron Hub Pilot 20,000 lbs. 10 Bolt 16.5x6in. or 7in. or air disc brakes. 10 Bolt, 11-1/4 in. bolt circle. Consider Wheelguards (5850002) with aluminum wheels. | -185 | 80 |
| 2741970 | S | ConMet PreSet Plus Hub Package; Front Axle. | 0 | 0 |
| 2750001 | S | Hubcap: Front Vented. | 0 | 0 |
| 2769000 | S | Slack Adjusters Included W/Front Axle or Brakes. Also use with disc brakes. | 0 | 0 |
| 2790015 | O | Front End Lowered: 1 in. Not Available W9B/L. | 0 | 0 |
| 2866020 | S | Front Springs: Taperleaf 20K W/ Shock Absorbers w/ maintenance-free elastomer spring pin bushings. Standard with rubber pins except for C500 which has threaded pins. Not available on W900L. W900B use 2866021. | 0 | 0 |
| 2893642 | O | Dual Power Steering Gear: 16-22K TRW THP60 Not for use on T3. | 73 | 54 |
| 2899336 | S | Power Steering Cooler:Radiator Mounted Air-to-Oil | 0 | 0 |
| 2900616 | O | Threaded Bushings for Taperleaf Spring 16K, 18/20K, 22K, 40K replacing rubber. | 103 | 0 |
| 2900903 | O | Front Bendix Air Disc Brake Dustshield includes pad air disc brakes only. | 72 | 1 |
| Rear Axle & Equipment | | | | |
| 3121444 | O | Dual Dana Spicer DSH40 Rear Axle rated at 40K w/ 11mm housing. Tandem rear axles. | -324 | -377 |
| 3200336 | O | Rear Axle Ratio - 3.36. | 0 | 0 |
| 3306001 | S | Dual Rear Bendix Air Disc Brakes for Dual rear axles to 46K capacity. | 0 | 0 |
| 3392604 | S | Splined Rotor for Dual Rear Air Disc Brake for use with aluminum hubs. | 0 | 0 |
| 3407050 | S | Dual Rear Hubs: Aluminum Hub Pilot 46K; 11.25" bolt circle. Requires "R" series outer ends. | 0 | 0 |
| 3441972 | S | ConMet PreSet Plus Hub Package; Dual Rear Axle. | 0 | 0 |
| 3465900 | S | Rear Slack Adjusters Included W/ Axle or Air disc brakes. | 0 | 0 |
| 3485002 | S | Spring Brakes Included W/ Dual Rear Air Disc brakes. | 0 | 0 |
| 3490902 | O | Rear Air Disc Brake Dustshields for Tandem axles; includes pads and rotor shields. | 828 | 12 |
| 3495226 | O | Bendix 4S/4M Anti-Lock Brake System. | -3,688 | 0 |
| 3500057 | O | Interaxle Driveline: 1 Dana SPL170XL Tandem Rear Axles Only | -159 | -2 |
| 3532130 | O | Wheel Differential Lock for Dana Spicer Axles | 2,740 | 37 |

| Sales Code | Std/ Opt | Description | \$ List | Weight |
|---------------------------|----------|------------------------------------------------------------------------------------------------------------------------------------------------------------------------------------------------------------|---------|--------|
| | | DSP40/DSP41(P)/DSH40(P)/DSH44(P)/D40-155 forward rear axle & rear rear. Under Speed Interlock is standard on T680. | | |
| 3744150 | O | Rear suspension: Tandem Neway ADZ246 46K. 54 in. axle spacing. Air suspension w/ 10 in. ride height. Includes air suspension dump valve, single leveling valve & cast brake spiders. | 4,166 | 226 |
| 3808131 | O | 1 Steerable Pusher: Watson-Challn 13.5K SL13 | 14,882 | 1,245 |
| 3820036 | O | 1 Steerable Pusher Brakes: Bendix Non-RSD 15x4 Use with 13.5K axle. | 0 | 0 |
| 3820523 | O | 1 Steerable Pusher Brake Drum 15x4 for Use With 13.5K axle. | 0 | 0 |
| 3821121 | O | 1 Steerable Pusher Hubs Aluminum Hub Pilot for use with 13.5K axle. | 0 | 0 |
| 3828334 | O | Pusher or Tag: Gauge/ Switch Dash-Mounted, Gauge LH driver's seat, regulator under driver door. | 0 | 0 |
| 3828401 | O | Pusher: Gauge Digital Display Single Pusher 1 | 0 | 0 |
| 3830145 | O | Delete Standard Heavy-Duty Air Springs for Rear suspension. | -24 | -28 |
| 3841136 | O | 1st Pusher Location: 136 in. From C/I Forward tandem axle or single rear axle. | 0 | 0 |
| Tires & Wheels | | | | |
| 4017217 | O * | Front Tires: Michelin XZUS2 315/80R22.5 20PR * | -251 | 98 |
| | | 42.8 in. Diameter, All Position.. 19.8 in. SLR. | | |
| 4217415 | O | Rear Tires: Michelin X Multi D 295/60R22.5 18PR | -1,192 | 8 |
| 4781954 | U | MN X LINE ENERGY Z295/60R22.5 | 586 | -16 |
| 4900008 | O | Rear Tire Quantity: 8 | 0 | 0 |
| 5045268 | O | Front Wheel: Alcoa 89U63 22.5X9 AL Ultra One High Polish Wheel. | -236 | -39 |
| 5245280 | O | Rear Wheel: Alcoa 89U64 22.5X9 AL Ultra One High Polish Wheel. | 2,612 | -96 |
| 5781580 | O | 1 Steerable Pusher: 2 Alcoa 89U64 22.5X9 AL Ultra One High Polish Wheel. | 713 | -24 |
| 5850040 | O | Wheelguards: All Axles. | 119 | 2 |
| 5859010 | O | Single Front Axle: 2 wheels Dura-Bright Mirror Polish Dura-Bright outboard surface of aluminum wheels. | 308 | 0 |
| 5859012 | O | Dual Rear Axle Wheels: 4 Wheels Dura-Bright Mirror Polish Dura-Bright outboard surface of outer dual or single aluminum wheels. | 820 | 0 |
| 5859031 | O | 1 Pusher: 2 Wheels Dura-Bright Mirror Polish Dura-Bright outboard surface of outboard wheels mounted same as front axle. For use on 1 steerable or 1 non-steerable pusher axles w/ single wheel. | 320 | 0 |
| 5900008 | O | Rear Wheel/Rim Quantity: 8 | 0 | 0 |

| Sales Code | Std/ Opt | Description | \$ List | Weight |
|------------------------------|----------|-----------------------------------------------------------------------------------------------------------------------------------------------------------------------------------------------------------------------------------------------------------------------------------------------------------------------------------------------------------------------------------------------------------------------------------------------------------------------------------------------------------------------------------------------------------------------------------------------|---------|--------|
| Frame & Equipment | | | | |
| 6056600 | O | Frame Rails: 10-3/4 x 3-1/2 x 3/8in. Steel 337in. to 416 in. Truck frame weight is 3.48 lb.-in. per pair of rails. Section modulus is 17.80, RBM is 2,132,000 in-lbs per rail. Frame rail availability may be restricted based upon application, axle/suspension capacity, fifth wheel setting, or component/dimensional specifications. The results of the engineering review may result in a change to the requested frame rail. If a change is required Kenworth Application Engineering will advise the dealer of the appropriate material specification for a substitute rail. | 1,001 | 619 |
| 6141600 | O | Full Steel Insert: for 10-5/8 in. or 10-3/4 in. Steel 337 in. to 416 in. or 2nd insert for 11-5/8 in. steel frame. Adds 1,149,000 in-lb to main rail RBM. Truck insert weight is 2.05 lb.-in. per pair of rails. Full frame insert length is equal to wheelbase plus rear frame cutoff plus dimension forward of front axle by model. See databook addendum section 7.2. | 2,785 | 776 |
| 6302461 | O | Bumper: Tapered Chrome Steel Channel. Requires a bumper setting code. | 598 | 63 |
| 6319485 | S | 48.5 in. Bumper Setting. Requires a Bumper Code. | 0 | 0 |
| 6324025 | O | Front Tow Hook: Center Mounted, Cast. Requires iron front drive brackets. | 303 | 28 |
| 6390001 | O | Steel Shackle Links. | 10 | 8 |
| 6391201 | O | Custom Frame Layout: One Chassis CFL FT: SAME AS #321581 CFL DEF: SAME AS #321581 CFL BBX: SAME AS #321581 CFL A/T: SAME AS #321581 CFL C/M: SAME AS #321581 | 1,380 | 0 |
| 6400641 | O | Battery Box Cantilever Aluminum BOC with Polished smooth aluminum cover. | 696 | 10 |
| 6409902 | O | Battery Box Location: RH Side. | 116 | 15 |
| 6451094 | O | T470, C5, T6, T8 Polished DPF/SCR or CNG Cover with step. For use w/ 2010 or later exhaust systems. For T8, use extended length polished battery box on opposite rail to match the length of under cab components. | 462 | 0 |
| 6490440 | O | Heavy-Duty BOC Crossmember Assembly. | 209 | 23 |
| 6679860 | O | Final End-of-Frame Cut-Off Dimension Will be modified to 61 in. to 65 in. | 0 | 0 |
| 6721102 | S | Rear Mudflap Arms: Betts B-25 Standard-Duty, straight. Includes B1732 mounting brackets as standard. | 0 | 0 |
| 6722000 | S | Rear Mudflap Shields: White Plastic Antisail W/ Kenworth logo. | 0 | 0 |
| 6742009 | S | Square End-of-Frame W/O Crossmember; Non-Towing. | 0 | 0 |

Fuel Tanks & Equip

| Sales Code | Std/ Opt | Description | \$ List | Weight |
|----------------------------|-----------------|--------------------------------------------------------------------------------------------------------------------------------------------------------------------------------------------------------------------------------------------------------------------------------------------------------------------------------------------------------------------------------------------------------------------------------------------------------------------------------------------------------------------------------------|----------------|---------------|
| 7210090 | O | Fuel Tank: 90 US Gallon 24.5 in. Aluminum Under replace. Class 8 fuel tanks w/o locking caps include an anti-siphon device on the filler neck. | 156 | -4 |
| 7722153 | S | Small Round DEF Tank, 14 Gallons. The DEF tank will be located on the side you specified. If you have specific configuration or body builder concerns, please utilize the Custom Frame Layout option. Standard capacity is calculated by fuel capacity of the vehicle and will accommodate two diesel fill-ups for every DEF fill-up. For 1:1 DEF fuel fill ratio, add 7889204. | 0 | 0 |
| 7831008 | O | 6 in. Wide Lower Fuel Tank Step, for One 22 in. or 24.5 in. tank LH. | 90 | 2 |
| 7840015 | O | Polish Only One Aluminum Tank. | 477 | 0 |
| 7840038 | O | Polished Cover for 1 DEF Tank Any Size. | 356 | 3 |
| 7880009 | O | Mechanical Anti-Roll Channel for One Tank. | 79 | 6 |
| 7889061 | O | Polished Stainless Steel Tank Straps for 1 Tank. | 87 | 0 |
| 7889206 | O | Minimum Required DEF to Fuel Fill Ratio. | 0 | 0 |
| 7889245 | S | Anti-Siphon Device in Fuel Tank Filler Neck. For any number of fuel tanks. | 0 | 0 |
| 7889604 | S | DEF Tank Location is LH. | 0 | 0 |
| 7920090 | O | Location: 90 gal fuel tank LH under cab | 0 | 0 |
| Cab & Equipment | | | | |
| 8025301 | S | Cab: Stamped Aluminum Cab with Panoramic Curved glass windshield. Standard with stamped aluminum doors, heavy duty in-swinging hinges, and triple sealed doors. Manufactured using self-piercing rivets and structural adhesive. Includes LED exterior marker lights and turn signals. | 0 | 0 |
| 8090604 | O | Hood: T880 Standard Length With Mechanically Fastened Fenders. 122.6 inch BBC. | 350 | 15 |
| 8098212 | O | Bright Engine Air Intake Chrome Trimmed Engine Air Intake on Both Sides of Hood | 109 | 0 |
| 8108003 | O | Ember Filter For Cabin Air. Used to keep embers out of the HVAC filter element. Cannot be used with code 8108002. | 52 | 2 |
| 8108011 | S | Cab HVAC - Day Cab and 40 in. Sleeper System With Defrost, A/C, and 48,000 BTU/hr Heater. Includes automatic temperature control with one touch defrost operation and dash mounted cab temperature and solar intensity sensors. Pleated fresh air filter and cabin recirculation air filter standard. The Kenworth HVAC system is designed to provide optimal heating and cooling in all operating environments without need for additional insulation. Cab HVAC without sleeper heater AC is available with 40in sleeper. | 0 | 0 |
| 8190138 | O | Shutoff Valves to Isolate Primary Heater Remote mounted on frame under cab. | 58 | 0 |

| Sales Code | Std/ Opt | Description | \$ List | Weight |
|-------------------|-----------------|----------------------------------------------------------------------------------------------------------------------------------------------------------------------------------------------------------------------------------------------------------------------------------------------------------------------------------------------------------------------------------------------------------|----------------|---------------|
| 8201043 | O | Kenworth Smartwheel: 18 in. Leather Wrapped With Integrated Radio and Cruise Controls. | 94 | 2 |
| 8201051 | O | Column Mtd Retarder Control, RH Side Use with Manual & Allison Transmissions Only. | 0 | 0 |
| 8201200 | S | Adjustable Telescoping Tilt Steering Column. | 0 | 0 |
| 8203060 | O | 5 Sets of Keys. Replaces Standard 2 Sets of Keys. | 32 | 0 |
| 8203162 | O | Switch To Operate Fan When Parking Brake Is Set & Air Conditioner Is On. | 33 | 0 |
| 8203196 | O | Dash Mounted Compact Trailer Brake Valve. Self Returning. | 0 | 0 |
| 8205135 | O | Information for Customer-Installed PTO Muncie 10-bolt. | 0 | 0 |
| 8205160 | O | Dash SW: Bendix Work Brake Electric Over Air SW To Apply All Service Brakes | 222 | 5 |
| 8205177 | O | Dash Switch:1st Allison-Mounted PTO. Electric switch and wiring are factory-installed to control the 1st Allison Trans mounted PTO. | 242 | 0 |
| 8208498 | O | Five Spare Switches: Wired to Power. | 192 | 0 |
| 8220106 | O | Gauge: Dash Mounted Air Filter Restriction Gauge. | 158 | 0 |
| 8221144 | O | Gauge: Air Suspension Pressure Gauge. | 143 | 0 |
| 8222404 | S | Gauge: DD Virtual Gauge - Oil Temp Engine | 0 | 0 |
| 8222413 | S | Gauge: DD Virtual Gauge - Manifold Pressure Boost | 0 | 0 |
| 8222414 | S | Gauge: DD Virtual Gauge - Engine Percent Torque | 0 | 0 |
| 8222712 | O | Gauge: Fuel Filter Restriction Gauge. | 139 | 0 |
| 8225658 | O | Gauge: Axle Oil Temperature, Dual-Drive Axle. (2 gauges) w/integral warning light. | 227 | 0 |
| 8282027 | S | Main Instrument Package: 15" Digital Display. Includes Speedometer, Tachometer, Primary Air Pressure, Secondary Air Pressure, Fuel Level #1, DEF Level, DPF Filter Status, Fuel Economy, Oil Pressure, Coolant Temp, OAT and Voltmeter, and Air Application. | 0 | 0 |
| 8300008 | S | Interior Color: Slate Gray | 0 | 0 |
| 8330102 | S | Interior Package: Vantage Daycab Includes durable headliner and vinyl sidewalls with geometric patterned trim and anodized aluminum accents throughout. Convenient overhead storage cubbies, full size glove box, two center console cupholders, and large door pad map pocket. Standard LH/RH power windows, electric door locks, interior LED lighting, nighttime-friendly red ambient lighting | 0 | 0 |

| Sales Code | Std/ Opt | Description | \$ List | Weight |
|------------|----------|-------------------------------------------------------------------------------------------------------------------------------------------------------------------------------------------------------------------------------------------------------------------------------------------------------------------------------------------------------------------------------------------------------------------------------------------------------------------------------------------------------------------------------------------|---------|--------|
| | | for dash and footwell, and door mounted courtesy light. Includes two standard 12V power outlets. Driver sunvisor includes strap. | | |
| 8390634 | S | Rubber Floormat | 0 | 0 |
| 8410277 | O | Driver Seat: GT702 HB with Ultraleather material and integral heat. The GT702 is standard with a single air bag, scissor linkage seat suspension that incorporates seat height memory, auto-leveling valves with exit air dump, and adjustable damper. It includes a dual chamber lumbar support, 10in Fore/Aft adjustment, 5in Up/Down adjustment with protection zones, 2.5in pan extension, 51 degree seat back recline, and 16 degree full seat tilt. Includes 3-point matching seat belts. DR seat standard w/ dual armrests. | 558 | 10 |
| 8460277 | O | Rider Seat: GT702 HB with Ultraleather material and integral heat. The GT702 is standard with a single air bag, scissor linkage seat suspension that incorporates seat height memory, auto-leveling valves with exit air dump, and adjustable damper. It includes a dual chamber lumbar support, 10in Fore/Aft adjustment, 5in Up/Down adjustment with protection zones, 2.5in pan extension, 51 degree seat back recline, and 16 degree full seat tilt. Includes 3-point matching seat belts. Rider seat standard w/ LH armrest. | 818 | 44 |
| 8490181 | S | Seat Color: Black | 0 | 0 |
| 8601881 | O | CB Radio: Cobra 29. W/ Header Mounted Quick release. Includes transceiver & separate speaker remote-mounted in headliner & dual CB antennas. Includes sound tracker & illuminated panel. | 589 | 11 |
| 8698982 | O | Mid Level Audio System - Daycab: High Performance Door and B-Pillar Speakers. | 49 | 4 |
| 8700196 | O | Turn Signal: Self-Cancelling | 273 | 0 |
| 8700283 | S | LH and RH Trip Ledge Rain Deflectors | 0 | 0 |
| 8700406 | O | Stainless Steel Permit Panel on Cab, Driver Side only | 108 | 0 |
| 8700663 | S | Kenworth TruckTech+: This system provides the World's Best reporting of engine and aftertreatment fault codes, as well as enhanced support for the truck owner through rapid communication of fault severity and recommended actions. This is standard on all Kenworth models with a PACCAR MX engine, Cummins X15 engine, PX engine or Natural Gas engine. | 0 | 0 |
| 8700966 | O | Kenworth NavPlus HD Navigation System: Vantage, Splendor, APEX, Summit, or Pinnacle interior. System hardware includes: head unit that mounts in radio opening and 7in. high resolution touchscreen display mounted in dash area four. Includes: Truck specific navigation by ALK, Sirius and XM satellite radio receiver. | 2,539 | 0 |
| 8800260 | O | Long Grabhandle RH Side Mounted to Side-of-Cab exhaust. | 67 | 2 |
| 8800262 | O | Long Grabhandle LH Side Mounted to Side-of-Cab exhaust. | 67 | 2 |
| 8800402 | S | Dual Cab Interior Grabhandles: A Pillar Mounted Dash Wrap and B Pillar Mounted Grabhandles | 0 | 0 |

| Sales Code | Std/ Opt | Description | \$ List | Weight |
|---------------------------------|----------|--------------------------------------------------------------------------------------------------------------------------------------------------------------------------------------------------------------------------------------------------------------------------------|---------|--------|
| 8832113 | S | Kenworth Daylite Door With Standard LHRH electric door locks and LHRH electric window controls. | 0 | 0 |
| 8841411 | S | Single Air Horn Under Cab. | 0 | 0 |
| 8850139 | S | Look-Down, Pass. Door, Black 11x6 | 0 | 0 |
| 8865003 | O | Aero Mirror: Dual Kenworth Chrome Aero. Motorized Heated Mirrors, 7in X 13in With Chrome Mirror Shell and Black Mirror Arms. Also Includes LHRH Heated 6in X 7in Convex Mirrors. Mirror Brackets Set For 8-1/2 ft Load Width. Mirror Controls Located On Driver Side Door Pad. | 358 | 0 |
| 8871446 | S | Rear Cab Stationary Window 19in x 36in | 0 | 0 |
| 8890101 | S | One-Piece Bonded-In Windshield With Curved Glass. Standard. | 0 | 0 |
| 8890135 | S | Exterior Stainless Steel Survivor. | 921 | 19 |
| 8890300 | O | Fender Close-Out: Below Headlamp, Behind bumper. *NOT available with 3-piece bumper. | 214 | 0 |
| 8890349 | S | Wheelwell Fender Extension: 2.5 Inches | 0 | 0 |
| 8890876 | S | Kenworth Cab/Sleeper Air Suspension. | 0 | 0 |
| 8891013 | O | Extreme Temperature Insulation: Daycab Additional cab side wall insulation with improved material properties over standard insulation package. | 159 | 0 |
| Lights & Instruments | | | | |
| 9010553 | S | Headlamps: SAE Dual Halogen Complex Reflector | 0 | 0 |
| 9022137 | S | Marker Lights: Five, Rectangular, LED | 0 | 0 |
| 9030016 | S | Turn Signal Lights: Flush Mounted LED. Mounted at top of fender wheel arc. | 0 | 0 |
| 9030052 | S | LED Stop, Turn, Tail: With Two LED Backup Lights and With An LED License Plate. | 0 | 0 |
| 9058085 | O | Switch, Wire, Indicator Light: C/I Flood 1st SW Thru Grommet Under Cab | 136 | 0 |
| 9090039 | S | Marker Lights: Interrupter Switch. Included in Turn Signal For All Models Except T3. The T3 Switch Is In The Dash. | 0 | 0 |
| 9090049 | S | Omit Brake Light with Engine Brake. Can only be selected when chassis also has engine brake. Cannot be used with options to delete engine brake. | 0 | 0 |
| 9090115 | O | Reflectors: Two Midframe | 24 | 0 |
| 9090126 | O | Electric Backup Alarm: Meets SAE J994 & OSHA requirements. | 175 | 4 |
| 9090849 | O | Polyswitches Replacing Fuses. Switch Will | 49 | 0 |

| Sales Code | Std/ Opt | Description | \$ List | Weight |
|--------------------------|----------|---------------------------------------------------------------------------------------------------------------------------------------------------------------------------------------------------------------------------------------------------------------------------------------------------------------------------------------------------------------------------|---------|--------|
| | | automatically reset after removal of excess load. | | |
| Air Equipment | | | | |
| 9101219 | O | Air Dryer: Bendix AD-HF Extended Purge Heated With Puraguard | 148 | 0 |
| 9108001 | S | Moisture Ejection Valve W/ Pull Cable Drain. | 0 | 0 |
| 9110020 | O | Full Truck Kit Gladhands mounted at end-of-frame. Seven-way female receptacle mounted at end-of-frame in taillamp bracket. Kit includes dash mounted trailer air supply valve, trailer hand control valve, and hoses/fittings for the valves. Dash mounted parking brake valve, tractor protection valve, and spring brake inversion/relay valves are standard. | 981 | 15 |
| 9140020 | S | Nylon Air Tubing in Frame & Cab, Excluding Hoses subject to excessive heat or flexing. | 0 | 0 |
| 9140085 | O | Bendix LQ-5 Ratio Valve: for Kenworth-Installed pusher/tag. LQ-5 valve limits the amount of air applied to the pusher brakes. Helps prevent lockup in lightly loaded conditions. | 174 | 2 |
| 9140254 | O | Locate Air Dryer Inside RH Rail BOC. This code requires the use of a custom frame layout code. | 0 | 0 |
| 9140328 | O | Trailer ABS Electric Supply Through SAE J560 7-pin connector per TMC RP137). | 0 | 0 |
| Extended Warranty | | | | |
| 9200021 | S | Base Warranty - Standard Service Heavy Duty 12 months / 100,000 miles / 160,000 km. | 0 | 0 |
| 9212651 | O | TruckTech+ RD - 3YR Sub Cummins Engines | 499 | 0 |
| 9220005 | O | Base Warranty: Emissions (CARB Operation) 5YR/350K MI - X15 PER/PRO Engine | 3,495 | 0 |
| Miscellaneous | | | | |
| 9409852 | O | GHG Secondary Manufacturer: Does Not Apply | 0 | 0 |
| 9490003 | O | Additional Lead Time Required for Off Highway & /or specialty component truck. | 0 | 0 |
| 9490206 | O | Warning Triangle Reflector Kit: Shipped Loose. Kit consists of 3 triangles in plastic carrying case. Not floor mounted. | 56 | 4 |
| 9490645 | O | Zinc Phosphate Frame Rail Paint Processing. Requires frame rail code. Code is for 1 pair of rails. | 405 | 0 |
| 9490647 | O | Zinc Phosphate Frame Insert Paint Processing. Requires any 1st frame insert code. Code is for 1 pair of any frame inserts. | 405 | 0 |
| 9491659 | S | VMUX Architecture | 0 | 0 |
| Promotions | | | | |
| Paint | | | | |
| 9700000 | O | Paint Color Number(s). | 0 | 0 |

| Sales Code | Std/ Opt | Description | \$ List | Weight |
|-------------------|-----------------|-----------------------------------------------------------------------------------------------------------------------------------------------------------------------------------------------------------------------------------------|----------------|---------------|
| | | N9702 A - L0006 WHITE N9720 FRAME N0001 BLACK | | |
| 9943004 | O | Bumper Unpainted | 0 | 0 |
| 9943048 | O | Day Cab Bulk Paint | 0 | 0 |
| 9943050 | O | Day Cab Standard Paint | 0 | 0 |
| 9944820 | S | 1 - Color Paint - Day Cab Color will be White if no other color is specified. | 0 | 0 |
| 9965510 | S | Base Coat/ Clear Coat. The Kenworth Color Selector contains additional instructions, as well as information on Kenworth paint guidelines and surface finish applications. Kenworth is standard with Dupont Imron Elite paint. | 0 | 0 |

Special Requirements

- Special Requirement 1 0098025
- Special Requirement 2
- Special Requirement 3
- Special Requirement 4

Order Comments

HORIZONTAL DIMENSIONS

** Revised **

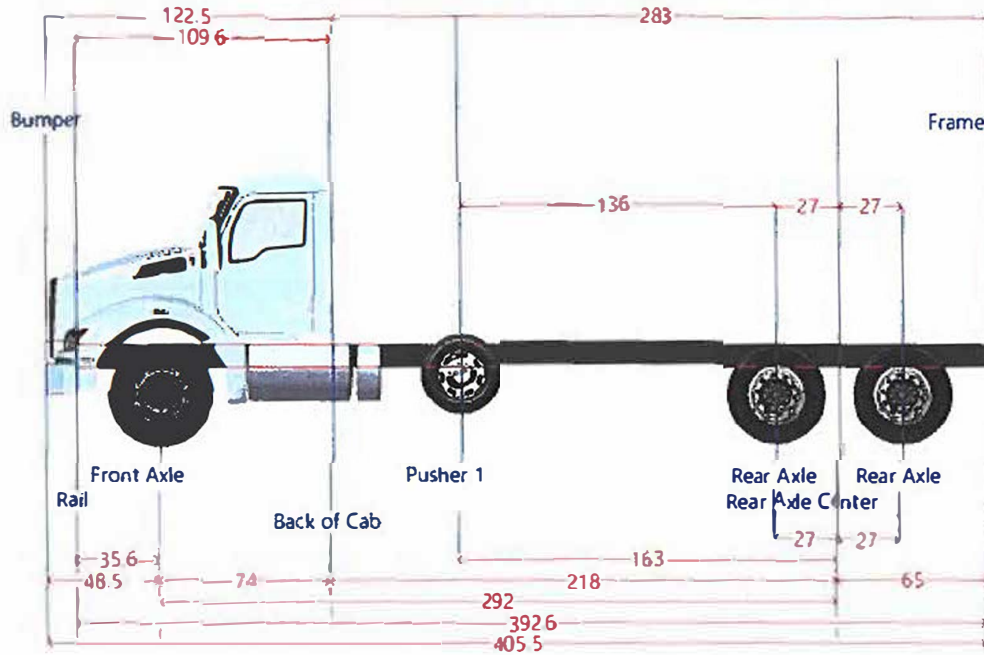

| Dimension | Measurement | Start | End |
|---------------------------------|-------------|-------|-------|
| Axle Spacing | 54 | 265 | 319 |
| Bumper to Back of Cab | 122.5 | -48.5 | 74 |
| Bumper to Front Axle | 48.5 | -48.5 | 0 |
| Bumper to Front Frame | 35.6 | -48.5 | -35.6 |
| Cab to End of Frame | 283.0 | 74 | 357 |
| Cab to Rear Axle | 218.0 | 74 | 292 |
| Effective Bumper to Back Of Cab | 122.5 | -48.5 | 74 |
| Frame Length | 392.6 | -35.6 | 357 |
| Front Axle to Back of Cab | 74.0 | 0 | 74 |
| Front of Frame to Axle | 35.6 | 35.6 | 0 |
| Load Space | 283.0 | 74 | 357 |
| Overall Length | 405.5 | -48.5 | 357 |
| Overhang | 65.0 | 292 | 357 |
| Pusher Offset #1 | 109.0 | 265 | 292 |
| Pusher Offset #2 | 27.0 | 265 | 292 |
| Pusher Offset #3 | 27.0 | 265 | 292 |
| Tag Offset | 7.0 | 292 | 319 |
| Wheelbase | 292 | 0 | 292 |

FRAME LAYOUT

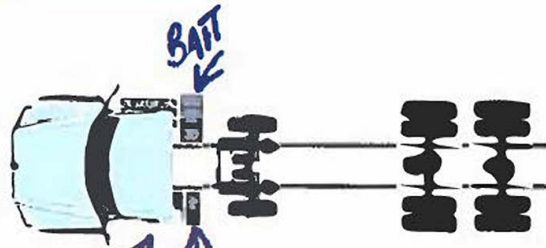

Note: Optional content may be displayed. The order has not yet received an engineering review. The actual arrangement of components may not be exactly as pictured. Additional changes may be made to the layout by Kenworth. Add a Custom Frame Layout code if an exact layout is required.

Selected Options (2/26/2014 29:11)

| Sales Code | Description | Length | Side |
|------------|----------------------------------------------------|--------|-------|
| 2312866 | Fuel Tank 90 US Gallon 24.5 in. Aluminum Tanker | 24.5 | Left |
| 7703143 | Gravel Retention Diff Tank 14 Gallons | 14 | Left |
| 940001 | Battery Box Can/cover Aluminum BOC with Parashield | 11.3 | Right |

Quote

156 Epping Rd.
 Exeter, NH 03833
 (603)778-8158
 www.netruckcenter.com

| | |
|-----------|------------|
| Date | Estimate # |
| 2/14/2024 | 488829 |

| |
|-----------------------------------------------------------------|
| Name / Address |
| New England Truck Center 156 Epping Road Exeter, NH 03833 |

| | |
|--------|-------|
| OP# | PO # |
| 488829 | STOCK |

| Item | Description | Qty | Total |
|-------------|--------------------------------------------------------------------|--------------|------------|
| Chassis | 2025 WHITE KENWORTH T880 LJ VIN# 124046 FET INCLUDED | 1 | 234,578.76 |
| 40-1411 | 2024 NRC 40TB-28' SERIAL# 40-1411 | 1 | 67,705.00 |
| FET Payable | BODY FET | 1 | 10,206.98 |
| C-NC21 | 40 000 TB | 1 | 0.00 |
| C-4028 | 28' - 40 000 TB | 1 | 0.00 |
| C-NC46 | COMPLETE EQUIPMENT | 1 | 0.00 |
| C-D415 | 5 CHAIN SLOTS PER SIDE (18 TOTAL FOR 25', 26', 27', 28', 29', 30') | 1 | 0.00 |
| C-D44-4 | SINGLE ROW OF (4) EXTRA CHAIN SLOTS IN THE CENTER OF DECK | 1 | 0.00 |
| C-DO | 1/4" STEEL CHECKER PLATE (STANDARD FOR 40 000-TB) | 1 | 0.00 |
| C-C3 | FLAT TOP DECK WITH STAKE POCKET, WITHOUT REMOVABLE RAILS | 1 | 0.00 |
| C-B3S | 3" HIGH X 9" SPACING (STANDARD FOR 30 000-TB AND 40 000-TB) | 1 | 0.00 |
| C-L16 | 5 MARKER LIGHTS PER SIDE | 1 | 0.00 |
| C-T04-1 | DP 20,000 LBS WITH 5/8" X 75' WIRE ROPE(STANDARD FOR 40 000-TB) | 1 | 0.00 |
| C-NC156 | WINCH AIR FREE SPOOL ON LEFT HAND SIDE (NC) | 1 | 0.00 |
| C-NC30 | 75' STEEL WIRE ROPE | 1 | 0.00 |
| C-CR01 | SWIVEL HOOK | 1 | 0.00 |
| C-NC25 | TANDEM AXLE | 1 | 0.00 |
| C-12V | 12V WIRING | 1 | 0.00 |
| C-E51 | HEAVY DUTY TOW BAR T-BAR 4" X 4" (STD) | 1 | 0.00 |
| C-G20 | GALVANIZED SUB-FRAME AND BUMPER | 1 | 0.00 |
| C-NC17 | CLEAR MARKER LIGHT | 1 | 0.00 |
| C-L118 | 8 X 4 1/2" LIGHT (6 RED (STOP-FLASH) / 2 BACKUPS) - ON BUMPER | 1 | 0.00 |
| C-NC11 | LEVER CONTROL STANDARDS | 1 | 0.00 |
| C-S052 | STAINLESS ON REAR BUMPER | 1 | 0.00 |
| | | Total | |

Quote

156 Epping Rd.
 Exeter, NH 03833
 (603)778-8158
 www.netruckcenter.com

| | |
|-----------|------------|
| Date | Estimate # |
| 2/14/2024 | 488829 |

| |
|-----------------------------------------------------------------|
| Name / Address |
| New England Truck Center 156 Epping Road Exeter, NH 03833 |

| | |
|--------|-------|
| OP# | PO # |
| 488829 | STOCK |

| Item | Description | Qty | Total |
|----------------------|--------------------------------------------------------------------------------------------------------------------------------------------------|--------------|-----------|
| C-G012 | STABILIZER GRIP (30,000 & 40,000 LBS) (4X4) | 1 | 0.00 |
| C-L112-1 | 2 LED WORK LIGHTS ON TOP OF THE REAR BUMPER | 1 | 0.00 |
| C-A432 | TRAILER HITCH & PINTLE HOOK ADAPTOR (4 HOLES) (T-BAR 4X4) | 1 | 0.00 |
| C-A1 | STANDARD CHAIN RACK | 1 | 0.00 |
| C-A12 | STD WINCH EMBEDDED IN CHAIN RACK | 1 | 0.00 |
| C-L118 | 8 X 4 1/2" LIGHT (6 RED (STOP-FLASH) / 2 BACKUPS) - ON CHAIN RACK | 1 | 0.00 |
| C-NC40 | CHAIN RACK NRC BLACK PAINT | 1 | 0.00 |
| C-S093 | STAINLESS ON SIDES AND HEAD OF CHAIN RACK | 1 | 0.00 |
| C-L112-1 | 2 LED WORK LIGHTS UNDER THE TOP OF THE CHAIN RACK | 1 | 0.00 |
| C-LO6P | WIRELESS REMOTE CONTROL LODAR 6 BUTTONS | 1 | 0.00 |
| C-A421 | RECOVERY ROLLER GUIDE (ROLLBACK) | 1 | 0.00 |
| C-S056 | STAINLESS ON OIL TANK | 1 | 0.00 |
| C-NC110 | WIRED TOWLIGHT ONLY | 1 | 0.00 |
| C-T6 | TOUCHPAD WITH FUSELESS LIGHTING SYSTEM CONTROLLER | 1 | 0.00 |
| C-P-O | NO NEW CUSTOM REQUEST | 1 | 0.00 |
| C-DISCLAIMER | CUSTOMER, FINAL PURCHASER OR END USER HAS BEEN INFORMED OF THE RISKS AND BENEFITS OF HOT DIP GALVANIZING (HDG) OF HIS NRC CAR CARRIER DECK | 1 | 0.00 |
| C-NC26 | "BLACK POLYMER CONTROL BOXES (STANDARD) | 1 | 0.00 |
| C-RACK6 | 74" (1880MM) - HEIGHT ABOVE FRAME RAILS (C#6) | 1 | 0.00 |
| C-PGAL-2 | DECK GALVANIZED (OPTION FOR 24'-30' DECKS) UNCONFIGURABLE ITEMS | 1 | 0.00 |
| DESTTRANSPORT | DESTINATION TRANSPORT CHARGE | 1 | 1,300.00 |
| 30/40TBINSTALL-IN... | DEALER INSTALL WITH PTO, HOSE TRACK, STANDARD STOCK PAINT AND DETAIL | 1 | 11,500.00 |
| 72AMBJUSTLB-INST | 72" AMBER JUSTICE LIGHT BAR INSTALLED | 1 | 2,450.00 |
| TU824003-INST | 60" BAWER STAINLESS TOOLBOX INSTALLED | 2 | 3,403.20 |
| | | Total | |

Quote

156 Epping Rd.
 Exeter, NH 03833
 (603)778-8158
 www.netruckcenter.com

| | |
|-----------|------------|
| Date | Estimate # |
| 2/14/2024 | 488829 |

| |
|-----------------------------------------------------------------|
| Name / Address |
| New England Truck Center 156 Epping Road Exeter, NH 03833 |

| | |
|--------|-------|
| OP# | PO # |
| 488829 | STOCK |

| Item | Description | Qty | Total |
|------|----------------------------------------------------------------------------------------------------|--------------|--------------|
| | **PRICING BASED OFF OF CURRENT DATA. PRICING SUBJECT TO CHANGE ONCE CLOSER TO BUILD TIME OF UNIT** | | |
| | | Total | \$331,143.94 |

ONCE THE BUYER ACCEPTS THIS ORDER, THE BUYER'S DEPOSIT IS NOT REFUNDABLE UNLESS THE BUYER CANNOT TAKE DELIVERY OF SAID VEHICLE(S) FOR A REASON BEYOND THE BUYER'S CONTROL. IN THAT EVENT, THE DEALER MAY, BUT WILL NOT BE REQUIRED TO, RETURN THE DEPOSIT TO THE BUYER, LESS ANY EXPENSES WHICH THE DEALER HAS INCURRED IN ACCEPTING AND PROCESSING THIS ORDER. THE BUYER'S FAILURE TO OBTAIN FINANCING BEFORE SCHEDULED DELIVERY IS NOT A REASON BEYOND THE BUYER'S CONTROL. THE BUYER WILL ALSO BE SUBJECT TO ANY PRICE INCREASES THAT ARE RECEIVED BY THE DEALER PERTAINING TO THE CHASSIS OR BODY. BY SIGNING THIS THE BUYER ACKNOWLEDGES HAVING READ AND AGREEING TO THESE TERMS AND CONDITIONS.

Signature _____



Terms & Conditions

- Once the buyer accepts this order, the buyer's deposit is not refundable unless the buyer cannot take delivery of the said vehicle(s) for a reason beyond the buyer's control. In that event, the dealer may, but will not be required to return the deposit to the buyer, less any expenses which the dealer has incurred in accepting and processing this order. The buyer's failure to obtain financing before scheduled delivery is not a reason beyond the buyer's control.
- The buyer will be subject to any price increase and or surcharge that are received by the dealer pertaining to the chassis or body.
- The buyer will be subject to any price increase on raw materials / parts that are incurred from the time of placing the order to the actual time of build and delivery of the unit(s).
- By signing this the buyer acknowledges having read and agreeing to these terms and conditions.

Date: _____

Signature of Purchaser: _____

Opp# _____ Chassis: _____ Body: _____

NETC Representative: _____

"Everything Truck"

156 Epping Road Exeter NH 03833 +1 603 778 8158

www.NEtruckcenter.com