



156 Epping Road Exeter, NH 03833

800-261-7219

Stock Number: STOCK KENWORTH T880

2026 Kenworth T880

Details:

- 2025 NRC 40TB - 28'
- Galvanized Deck and Subframe
- Ladar Remote
- 20k Winch
- Cummins X15
- 525HP
- Allison 4500RDS 6-speed
- Full Chassis / Body spec attached

Price: \$331,180



NEW ENGLAND TRUCK CENTER
 156 EPPING RD
 EXETER, New Hampshire 03833
 United States of America

Mike

Vehicle Summary

	Unit		Chassis	
Model:	T880 Series Conventional	Fr Axle Load (lbs):		20000
Type:	FULL TRUCK	Rr Axle Load (lbs):		40000
Description 1:	T880 NON LJ	G.C.W. (lbs):		80000
Description 2:				
	Application	Road Conditions:		
Intended Serv.:	Heavy equipment transport. Vehicles	Class A (Highway)		95
	us			
Commodity:	Heavy Machinery	Class B (Hwy/Mtn)		5
		Class C (Off-Hwy)		0
		Class D (Off-Road)		0
	Body	Maximum Grade:		6
Type:	Flatbed	Wheelbase (in):		292
Length (ft):	24	Overhang (in):		65
Height (ft):	12	Fr Axle to BOC (in):		74
Max Laden Weight (lbs):	8000			
		Cab to Axle (in):		218
		Cab to EOF (in):		283
	Trailer	Overall Comb. Length (in):		405.5
No. of Trailer Axles:	0			
Type:				
Length (ft):	0			
Height (ft):	0	Special Req.		
Kingpin Inset (in):	0	U.S. Domestic Registry, 50-state.		
Corner Radius (in):	0			
	Restrictions			
Length (ft):	40			
Width (in):	102			
Height (ft):	15			

Approved by: _____

Date: _____

Note: All sales are F.O.B. designated plant of manufacture.

Sales Code	Std/ Opt	Description	\$ List	Weight
Model				
0000810	S	T880 Series Conventional	234,126	15,549
0070060	S	T880	0	0
0072000	O	Chassis Operation Will Not Incl. Stationary application. Stationary operation is defined as running the engine under load while stationary at a substantial fraction of engine gross horsepower (60% or greater) for an extended period of time (longer than 5 - 10 minutes).	0	0
0080055	O	CARB Clean Idle Label - Cummins Engines	106	0
0080310	O	EPA Clean Idle Label - Cummins Engines	107	0
0090000	S	Non-Sleeper w/ Rear Axle Capacity less than 59K.	0	0
0098429	O	State of Registry: New Hampshire	0	0
Engine & Equipment				
0130359	O	Cummins X15 525 525@1900 1850@1000, 2024 with Intebrake, Performance Series N09420 C333 0.....Reserve Speed Limit Offset (N09380 C334 0.....Maximum Cycle Distance (C334 N09360 C400 252...Reserve Speed Function Reset N09200 C399 120...Standard Maximum Speed Limit N09400 C401 10.....Maximum Active Distance (C40 N09220 C402 0.....Expiration Distance (C402) N09540 C395 0.....Expiration Distance (C395) N09260 C121 64.....Maximum Accelerator Pedal Ve N09440 C234 YES...Engine Protection Shutdown (N09460 C231 YES...Gear Down Protection (C231) N09580 C133 5.....Timer Setting (C133) N09680 C233 NO.....Idle Shutdown Manual Overrul N09480 C132 1400..Max PTO Speed (C132) N09300 C128 64.....Maximum Cruise Speed (C128) N09500 C239 YES...Cruise Control Auto Resume (N09520 C238 YES...Auto Engine Brake in Cruise N09240 C209 120...Hard Maximum Speed Limit (C2 N09780 C190 80.....High Ambient Temperature Thr N09740 C188 40.....Low Ambient Temperature Thre N09760 C189 60.....Intermediate Ambient Tempera N09720 C382 YES...Enable Hot Ambient Automatic N09600 C396 YES...Enable Impending Shutdown Wa N09620 C397 60.....Timer For Impending Shutdown N09640 C206 35.....Engine Load Threshold (C206) N09560 C225 YES...Enable Idle Shutdown Park Br	11,711	336
1000047	O	CARB Emissions Warranty Engine	0	0

Sales Code	Std/Opt	Description	\$ List	Weight
1000151	S	PremierSpec	0	0
1000244	O	Gearing Analysis: Balance power/economy blend results.	0	0
1000256	O	Customer's Typical Operating Spd: 64 MPH	0	0
1000525		RegistrationYear Year of Registration: 2025	0	0
1000684	O	Effective VSL Setting NA	0	0
1000858	O	Engine Idle Shutdown Timer Disabled	0	0
1000891	O	Eff EIST NA Expiration Miles Use only with MX and Cummins engines	0	0
1002080	O	Air Compressor: Cummins 18.7 CFM, Naturally Aspirated for Cummins X15 engines	211	0
1051200	S	Air Cleaner: Composite Firewall Mounted PACCAR or Cummins Engines	0	0
1105220	O	Fan Hub: Horton 2-Speed for X15/X15N	24	0
1123555	S	Cooling module: 1330 square inches. Includes aluminum radiator core, aluminum charge air cooler, translucent surge tank and washer bottle, silicone hoses, and extended life coolant.	0	0
1160208	O	Bug Screen: Between Hood & Grille	128	2
1247251	O	EXH: Single Can 2024 RH Under with Dual Side-of-Cab Tailpipes	1,525	-422
1290436	O	Tailpipe: 7 in. dual 36 in. 45 degree curved.	649	8
1292944	O	Dual Lower Chrome Exhaust Elbow	692	0
1321109	O	Fuel Filter:PACCAR Standard Service Interval Fuel/Water Separator. 2017 and Later Emissions	74	0
1321205	S	Run Aid:Fuel Heat *For Fuel Filter	0	0
1321305	S	Start Aid:12V Heat *For Fuel Filter	0	0
1500029	O	Kenworth Fuel Cooler Required for Cummins engines with a single fuel tank. Required for PACCAR MX-13 engine with a single fuel tank and stationary use: High RPM, low vehicle speed, sustained for longer than 1 hour. Optional for all other applications.	219	6
1504005	O	Immersion Block Heater 120V 1500W W/ Plug Under Door on C500, T660, T800 & W900.	150	2
1812163	S	Alternator: PACCAR HDS 160 AMP Brushed	0	0
1821210	S	Batteries: 3 PACCAR GP31 Threaded Post (700-730) 2100-2190 CCA dual purpose.	0	0

Sales Code	Std/Opt	Description	\$ List	Weight
1836106	O	Mitsubishi 105P55 12V Starter with Cummins and PX PACCAR 12 volt electrical system. W/ centralized power distribution incorporating plug-in style relays. Circuit protection for serviceability, 12-volt light system w/circuit protection circuits number & color coded. Only for Cummins or PX engines.	0	0
1840065	S	12V Low Voltage Disconnect for Battery Protection	0	0
1901017	S	Remote PTO/Throttle, 12-PIn, Engine Bay Remote Control Provision	0	0

Transmission & Clutch

2016627	O	Transmission: Allison 450RDS 6-speed, With PTO drive gear. No Retarder. 6th Generation controls. For vocational applications. Includes shift control, transmission oil temperature gauge, oil level sensor & heat exchanger. Transynd transmission fluid is standard on all Allison 1000, 2000, 3000 & 4000 series transmissions.	26,055	478
2406803	O	Driveline: 3 Dana SPL250XL W/ 2 Centerbearings Low maintenance offering from Spicer. On-highway 350K mi first service interval, 100K mi subsequent service interval on U-joint, splines lubed for life, quick disconnect end caps.	2,339	187
2410018	O	Torque Converter Included W/ Allison Transmission.	0	0
2410151	O	Pushbutton Control Center Console Mounted. Class 8 with Allison Transmission.	0	0
2410204	O	Allison Fuel Sense: Delete	0	0
2410244	O	J1939 Park Brake Auto Neutral	0	0
2410310	O	Allison Neutral at Stop	0	0
2429358	O	Rear Transmission Support Springs for transmission PTO applications are required to ensure that engine flywheel housings are not overloaded when transmission PTO's are installed.	92	0
2429378	O	Customer Installed Transmission PTO in the LH Mounted position (8 o'clock) for Allison 3000 & 4000 transmissions.	0	0
2495023	O	Two Steel Centerbearing Crossmembers Installed with Heavy-Duty Aluminum Gussets Replacing Standard.	490	70

Front Axle & Equipment

2536002	S	PACCAR FX-20 Front Axle rated at 20K 4" drop standard track	0	0
2607002	S	Front Brakes: 14,601-22K Bendix Air Disc Brakes.	0	0
2690025	O	Splined Rotor for Front Air Disc Brakes for Use with Iron Hubs.	-199	0
2690039	S	Integral Knuckle for Air Disc Brake, for use on PACCAR FX Steer Axle	0	0
2702020	O	Front Hubs Iron Hub Pilot 20,000 lbs. 10 Bolt	-185	80

Sales Code	Std/Opt	Description	\$ List	Weight
		16.5x6in. or 7in. or air disc brakes. 10 Bolt, 11-1/4 in. bolt circle. Consider Wheelguards (5850002) with aluminum wheels.		
2741970	S	ConMet PreSet Plus Hub Package; Front Axle.	0	0
2750001	S	Hubcap: Front Vented.	0	0
2769000	S	Slack Adjusters Included W/ Front Axle or Brakes. Also use with disc brakes.	0	0
2790015	O	Front End Lowered: 1 in. Not Available W9B/L.	0	0
2866020	S	Front Springs: Taperleaf 20K W/ Shock Absorbers w/ maintenance-free elastomer spring pin bushings. Standard with rubber pins except for C500 which has threaded pins. Not available on W900L. W900B use 2866021.	0	0
2893642	O	Dual Power Steering Gear: 16-22K TRW THP60 Not for use on T3.	73	54
2899336	S	Power Steering Cooler: Radiator Mounted Air-to-Oil	0	0
2900616	O	Threaded Bushings for Taperleaf Spring 16K, 18/20K, 22K, 40K replacing rubber.	103	0
2900903	O	Front Bendix Air Disc Brake Dustshield includes pad air disc brakes only.	72	1
Rear Axle & Equipment				
3121444	O	Dual Dana Spicer DSH40 Rear Axle rated at 40K w/ 11mm housing. Tandem rear axles.	-324	-377
3200336	O	Rear Axle Ratio - 3.36.	0	0
3306001	S	Dual Rear Bendix Air Disc Brakes for Dual rear axles to 46K capacity.	0	0
3392604	S	Spined Rotor for Dual Rear Air Disc Brake for use with aluminum hubs.	0	0
3407050	S	Dual Rear Hubs: Aluminum Hub Pilot 46K; 11.25" bolt circle. Requires "R" series outer ends.	0	0
3441972	S	ConMet PreSet Plus Hub Package; Dual Rear Axle.	0	0
3465900	S	Rear Slack Adjusters Included W/ Axle or Air disc brakes.	0	0
3485002	S	Spring Brakes Included W/ Dual Rear Air Disc brakes.	0	0
3490902	O	Rear Air Disc Brake Dustshields for Tandem axles; includes pads and rotor shields.	828	12
3495226	O	Bendix 4S/4M Anti-Lock Brake System.	-3,688	0
3500057	O	Interaxle Driveline: 1 Dana SPL170XL Tandem Rear Axles Only	-159	-2
3532130	O	Wheel Differential Lock for Dana Spicer Axles DSP40/DSP41(P)/DSH40(P)/DSH44(P)/D40-155 forward rear axle & rear rear. Under Speed Interlock is standard on T680.	2,740	37

Sales Code	Std/ Opt	Description	\$ List	Weight
3744150	O	Rear suspension: Tandem Neway ADZ246 46K. 54 in. axle spacing. Air suspension w/ 10 in. ride height. Includes air suspension dump valve, single leveling valve & cast brake spiders.	4,166	226
3808131	O	1 Steerable Pusher: Watson-Challn 13.5K SL13	14,882	1,245
3820050	O	1 Steerable Pusher Disc Brakes And Splined Rotor: Bendix Non-RSD Use With 13.5K Axle	5,536	42
3821121	O	1 Steerable Pusher Hubs Aluminum Hub Pilot for use with 13.5K axle.	0	0
3828339	O	Pusher or Tag: Gauge/ Switch Dash-Mounted; Gauge and pressure regulator mounted left of driver.	0	0
3828401	O	Pusher: Gauge Digital Display Single Pusher 1	0	0
3830145	O	Delete Standard Heavy-Duty Air Springs for Rear suspension.	-24	-28
3841054	O	1st Pusher Location: 54 in. From C/I Forward tandem axle or single rear axle.	0	0

Tires & Wheels

4017217	O	Front Tires: Michelin XZUS2 315/80R22.5 20PR 42.8 in. Diameter, All Position.. 19.8 in. SLR.	-251	98
4217415	O	Rear Tires: Michelin X Multi D 295/60R22.5 18PR	-1,192	8
4781954	U	STRBL PSHR MN X LINE	588	-15
4900008	O	Rear Tire Quantity: 8	0	0
5045268	O	Front Wheel: Alcoa 89U63 22.5X9 AL Ultra One High Polish Wheel.	-236	-39
5245280	O	Rear Wheel: Alcoa 89U64 22.5X9 AL Ultra One High Polish Wheel.	2,612	-96
5781568	O	1 Steerable Pusher Wheel: 2 Alcoa 89U63 22.5X9 AL Ultra One High Polish Wheel.	728	-39
5850040	O	Wheelguards: All Axles.	119	2
5859010	O	Single Front Axle: 2 wheels Dura-Bright Mirror Polish Dura-Bright outboard surface of aluminum wheels.	308	0
5859012	O	Dual Rear Axle Wheels: 4 Wheels Dura-Bright Mirror Polish Dura-Bright outboard surface of outer dual or single aluminum wheels.	820	0
5859031	O	1 Pusher: 2 Wheels Dura-Bright Mirror Polish Dura-Bright outboard surface of outboard wheels mounted same as front axle. For use on 1 steerable or 1 non-steerable pusher axles w/ single wheel.	320	0
5900008	O	Rear Wheel/Rim Quantity: 8	0	0

Frame & Equipment

6056600	O	Frame Rails: 10-3/4 x 3-1/2 x 3/8In. Steel 337In.	1,001	619
---------	---	--	-------	-----

Sales Code	Std/ Opt	Description	\$ List	Weight
		to 416 in. Truck frame weight is 3.48 lb.-in. per pair of rails. Section modulus is 17.80, RBM is 2,132,000 in-lbs per rail. Frame rail availability may be restricted based upon application, axle/suspension capacity, fifth wheel setting, or component/dimensional specifications. The results of the engineering review may result in a change to the requested frame rail. If a change is required Kenworth Application Engineering will advise the dealer of the appropriate material specification for a substitute rail.		
6141600	O	Full Steel Insert: for 10-5/8 in. or 10-3/4 in. Steel 337 in. to 416 in. or 2nd insert for 11-5/8 in. steel frame. Adds 1,149,000 in-lb to main rail RBM. Truck insert weight is 2.05 lb.-in. per pair of rails. Full frame insert length is equal to wheelbase plus rear frame cutoff plus dimension forward of front axle by model. See databook addendum section 7.2.	2,785	776
6302461	O	Bumper: Tapered Chrome Steel Channel. Requires a bumper setting code.	598	63
6319485	S	48.5 in. Bumper Setting. Requires a Bumper Code.	0	0
6324025	O	Front Tow Hook: Center Mounted, Cast. Requires iron front drive brackets.	303	28
6390001	O	Steel Shackle Links.	10	8
6391201	O	Custom Frame Layout: One Chassis CFL A/D: SAME AS #132294 CFL FT: SAME AS #132294 CFL C/M: SAME AS #132294 CFL BBX: SAME AS #132294 CFL A/T: SAME AS #132294 CFL DEF: SAME AS #132294	1,380	0
6400641	O	Battery Box Cantilever Aluminum BOC with Polished smooth aluminum cover.	696	10
6409902	O	Battery Box Location: RH Side.	116	15
6451094	O	T470, C5, T6, T8 Polished DPF/SCR or CNG Cover with step. For use w/ 2010 or later exhaust systems. For T8, use extended length polished battery box on opposite rail to match the length of under cab components.	462	0
6490440	O	Heavy-Duty BOC Crossmember Assembly.	209	23
6721102	S	Rear Mudflap Arms: Betts B-25 Standard-Duty, straight. Includes B1732 mounting brackets as standard.	0	0
6722000	S	Rear Mudflap Shields: White Plastic Antisail W/ Kenworth logo.	0	0
6742009	S	Square End-of-Frame W/O Crossmember; Non-Towing.	0	0
Fuel Tanks & Equip				
7210090	O	Fuel Tank: 90 US Gallon 24.5 in. Aluminum Under replace. Class 8 fuel tanks w/o locking caps include an anti-siphon device on the filler neck.	156	-4
7722153	S	Small Round DEF Tank, 14 Gallons.	0	0

Sales Code	Std/ Opt	Description	\$ List	Weight
		The DEF tank will be located on the side you specified. If you have specific configuration or body builder concerns, please utilize the Custom Frame Layout option. Standard capacity is calculated by fuel capacity of the vehicle and will accommodate two diesel fill-ups for every DEF fill-up. For 1:1 DEF fuel fill ratio, add 7889204.		
7831008	O	6 in. Wide Lower Fuel Tank Step, for One 22 in. or 24.5 in. tank LH.	90	2
7840015	O	Polish Only One Aluminum Tank.	477	0
7840038	O	Polished Cover for 1 DEF Tank Any Size.	356	3
7880009	O	Mechanical Anti-Roll Channel for One Tank.	79	6
7889061	O	Polished Stainless Steel Tank Straps for 1 Tank.	87	0
7889208	O	DEF to fuel fill ratio between 1.25:1 and 2:1.	0	0
7889245	S	Anti-Siphon Device in Fuel Tank Filler Neck. For any number of fuel tanks.	0	0
7889604	S	DEF Tank Location Is LH.	0	0
7920090	O	Location: 90 gal fuel tank LH under cab	0	0
Cab & Equipment				
8025301	S	Cab: Stamped Aluminum Cab with Panoramic Curved glass windshield. Standard with stamped aluminum doors, heavy duty in-swinging hinges, and triple sealed doors. Manufactured using self-piercing rivets and structural adhesive. Includes LED exterior marker lights and turn signals.	0	0
8090604	O	Hood: T880 Set-Back Medium Length. 122.6 inch BBC W/Std Bumper.	350	15
8098212	O	Bright Engine Air Intake Chrome Trimmed Engine Air Intake on Both Sides of Hood	109	0
8108003	O	Ember Filter For Cabin Air. Used to keep embers out of the HVAC filter element. Cannot be used with code 8108002.	52	2
8108011	S	Cab HVAC - Day Cab and 40 in. Sleeper System With Defrost, A/C, and 48,000 BTU/hr Heater. Includes automatic temperature control with one touch defrost operation and dash mounted cab temperature and solar intensity sensors. Pleated fresh air filter and cabin recirculation air filter standard. The Kenworth HVAC system is designed to provide optimal heating and cooling in all operating environments without need for additional insulation. Cab HVAC without sleeper heater AC is available with 40in sleeper.	0	0
8190138	O	Shutoff Valves to Isolate Primary Heater Remote mounted on frame under cab.	58	0
8201043	O	Kenworth Smartwheel: 18 in. Leather Wrapped With Integrated Radio and Cruise Controls.	94	2
8201051	O	Column Mtd Retarder Control, RH Side Use with Manual & Allison Transmissions Only.	0	0

Sales Code	Std/ Opt	Description	\$ List	Weight
8201200	S	Adjustable Telescoping Tilt Steering Column.	0	0
8203060	O	5 Sets of Keys. Replaces Standard 2 Sets of Keys.	32	0
8203162	O	Switch To Operate Fan When Parking Brake Is Set & Air Conditioner Is On.	33	0
8203196	O	Dash Mounted Compact Trailer Brake Valve. Self Returning.	0	0
8205135	O	Information for Customer-Installed PTO Muncie 10-bolt.	0	0
8205160	O	Dash SW: Bendix Work Brake Electric Over Air SW To Apply All Service Brakes	222	5
8205177	O	Dash Switch:1st Allison-Mounted PTO. Electric switch and wiring are factory-installed to control the 1st Allison Trans mounted PTO.	242	0
8208498	O	Five Spare Switches: Wired to Power.	192	0
8220106	O	Gauge: Dash Mounted Air Filter Restriction Gauge.	158	0
8221144	O	Gauge: Air Suspension Pressure Gauge.	143	0
8222404	S	Gauge: DD Virtual Gauge - Oil Temp Engine	0	0
8222413	S	Gauge: DD Virtual Gauge - Manifold Pressure Boost	0	0
8222414	S	Gauge: DD Virtual Gauge - Engine Percent Torque	0	0
8222712	O	Gauge: Fuel Filter Restriction Gauge.	139	0
8225658	O	Gauge: Axle Oil Temperature, Dual-Drive Axle. (2 gauges) w/integral warning light.	227	0
8282027	S	Main Instrument Package: 15" Digital Display. Includes Speedometer, Tachometer, Primary Air Pressure, Secondary Air Pressure, Fuel Level #1, DEF Level, DPF Filter Status, Fuel Economy, Oil Pressure, Coolant Temp, OAT and Voltmeter, and Air Application.	0	0
8300008	S	Interior Color: Slate Gray	0	0
8330102	S	Interior Package: Vantage Daycab Includes durable headliner and vinyl sidewalls with geometric patterned trim and anodized aluminum accents throughout. Convenient overhead storage cubbies, full size glove box, two center console cupholders, and large door pad map pocket. Standard LH/RH power windows, electric door locks, interior LED lighting, nighttime-friendly red ambient lighting for dash and footwell, and door mounted courtesy light. Includes two standard 12V power outlets. Driver sunvisor includes strap.	0	0
8390634	S	Rubber Floormat	0	0

Sales Code	Std/ Opt	Description	\$ List	Weight
8410277	O	Driver Seat: GT702 HB with Ultra leather material and integral heat. The GT702 is standard with a single air bag, scissor linkage seat suspension that incorporates seat height memory, auto-leveling valves with exit air dump, and adjustable damper. It includes a dual chamber lumbar support, 10in Fore/Aft adjustment, 5in Up/Down adjustment with protection zones, 2.5in pan extension, 51 degree seat back recline, and 16 degree full seat tilt. Includes 3-point matching seat belts. DR seat standard w/ dual armrests.	558	10
8460277	O	Rider Seat: GT702 HB with Ultra leather material and integral heat. The GT702 is standard with a single air bag, scissor linkage seat suspension that incorporates seat height memory, auto-leveling valves with exit air dump, and adjustable damper. It includes a dual chamber lumbar support, 10in Fore/Aft adjustment, 5in Up/Down adjustment with protection zones, 2.5in pan extension, 51 degree seat back recline, and 16 degree full seat tilt. Includes 3-point matching seat belts. Rider seat standard w/ LH armrest.	818	44
8490181	S	Seat Color: Black	0	0
8601440	O	Kenworth Radio and Navigation: compatible with Apple Carplay	1,220	0
8601881	O	CB Radio: Cobra 29. W/ Header Mounted Quick release. Includes transceiver & separate speaker remote-mounted in headliner & dual CB antennas. Includes sound tracker & illuminated panel.	589	11
8698982	O	Mid Level Audio System - Daycab: High Performance Door and B-Pillar Speakers.	49	4
8700196	O	Turn Signal: Self-Cancelling	273	0
8700283	S	LH and RH Trip Ledge Rain Deflectors	0	0
8700406	O	Stainless Steel Permit Panel on Cab, Driver Side only	108	0
8700601	S	Global Telematics Unit	0	0
8800260	O	Long Grabhandle RH Side Mounted to Side-of-Cab exhaust.	67	2
8800262	O	Long Grabhandle LH Side Mounted to Side-of-Cab exhaust.	67	2
8800402	S	Dual Cab Interior Grabhandles: A Pillar Mounted Dash Wrap and B Pillar Mounted Grabhandles	0	0
8832113	S	Kenworth Daylite Door With Standard LH/RH electric door locks and LH/RH electric window controls.	0	0
8841411	S	Single Air Horn Under Cab.	0	0
8850139	S	Look-Down, Pass. Door, Black 11x6	0	0
8865003	O	Aero Mirror: Dual Kenworth Chrome Aero. Motorized Heated Mirrors, 7in X 13in With Chrome Mirror Shell and Black Mirror Arms. Also Includes LH/RH Heated 6in X 7in Convex Mirrors. Mirror	358	0



Sales Code	Std/ Opt	Description	\$ List	Weight
		Brackets Set For 8-1/2 ft Load Width. Mirror Controls Located On Driver Side Door Pad.		
8871446	S	Rear Cab Stationary Window 19In x 36In	0	0
8890101	S	One-Piece Bonded-In Windshield With Curved Glass. Standard.	0	0
8890135	S	Exterior Stainless Steel Sunvisor.	921	19
8890300	O	Fender Close-Out: Below Headlamp, Behind bumper. *NOT available with 3-piece bumper.	214	0
8890349	S	Wheelwell Fender Extension: 2.5 Inches	0	0
8890876	S	Kenworth Cab/Sleeper Air Suspension.	0	0
8891013	O	Extreme Temperature Insulation: Daycab Additional cab side wall insulation with improved material properties over standard insulation package.	159	0
Lights & Instruments				
9010553	S	Headlamps: SAE Dual Halogen Complex Reflector	0	0
9022137	S	Marker Lights: Five, Rectangular, LED	0	0
9030016	S	Turn Signal Lights: Flush Mounted LED. Mounted at top of fender wheel arc.	0	0
9030052	S	LED Stop, Turn, Tail: With Two LED Backup Lights and With An LED License Plate.	0	0
9058085	O	Switch, Wire, Indicator Light: C/I Flood 1st SW Thru Grommet Under Cab	136	0
9090039	S	Marker Lights: Interrupter Switch. Included In Turn Signal For All Models Except T3. The T3 Switch Is In The Dash.	0	0
9090049	S	Omit Brake Light with Engine Brake. Can only be selected when chassis also has engine brake. Cannot be used with options to delete engine brake.	0	0
9090115	O	Reflectors: Two Midframe	24	0
9090126	O	Electric Backup Alarm: Meets SAE J994 & OSHA requirements.	175	4
9090849	O	Polyswitches Replacing Fuses. Switch Will automatically reset after removal of excess load.	49	0
Air Equipment				
9101219	O	Air Dryer: Bendix AD-HF Extended Purge Heated With Puraguard	148	0
9108001	S	Moisture Ejection Valve W/ Pull Cable Drain.	0	0
9110020	O	Full Truck Kit	981	15



Sales Code	Std/Opt	Description	\$ List	Weight
		Gladhands mounted at end-of-frame. Seven-way female receptacle mounted at end-of-frame in taillamp bracket. Kit includes dash mounted trailer air supply valve, trailer hand control valve, and hoses/fittings for the valves. Dash mounted parking brake valve, tractor protection valve, and spring brake inversion/relay valves are standard.		
9140020	S	Nylon Air Tubing in Frame & Cab, Excluding Hoses subject to excessive heat or flexing.	0	0
9140085	O	Bendix LQ-5 Ratio Valve: for Kenworth-Installed pusher/tag. LQ-5 valve limits the amount of air applied to the pusher brakes. Helps prevent lockup in lightly loaded conditions.	174	2
9140328	O	Trailer ABS Electric Supply Through SAE J560 7-pin connector per TMC RP137).	0	0
Extended Warranty				
9200021	S	Base Warranty - Standard Service Heavy Duty 12 months / 100,000 miles / 160,000 km.	0	0
9212653	O	TruckTech+ RD - 5YR Sub Cummins Engines	799	0
9220005	O	Base Warranty: Emissions (CARB Operation) 5YR/350K MI - X15 PER/PRO Engine	3,495	0
Miscellaneous				
9409852	O	GHG Secondary Manufacturer: Does Not Apply	0	0
9490003	O	Additional Lead Time Required for Off Highway & /or specialty component truck.	0	0
9490206	O	Warning Triangle Reflector Kit: Shipped Loose. Kit consists of 3 triangles in plastic carrying case. Not floor mounted.	56	4
9490645	O	Zinc Phosphate Frame Rail Paint Processing. Requires frame rail code. Code is for 1 pair of rails.	405	0
9490647	O	Zinc Phosphate Frame Insert Paint Processing. Requires any 1st frame insert code. Code is for 1 pair of any frame inserts.	405	0
9491652	S	EMUX Architecture	0	0
Promotions				
Paint				
9700000	O	Paint Color Number(s). N9702 A - L0001 BLACK N9720 FRAME N0001 BLACK	0	0
9943004	O	Bumper Unpainted	0	0
9943048	O	Day Cab Bulk Paint	0	0
9943050	O	Day Cab Standard Paint	0	0



Sales Code	Std/ Opt	Description	\$ List	Weight
9944820	S	1 - Color Paint - Day Cab Color will be White if no other color is specified.	0	0
9965510	S	Base Coat/ Clear Coat. The Kenworth Color Selector contains additional instructions, as well as information on Kenworth paint guidelines and surface finish applications. Kenworth is standard with Dupont Imron Elite paint.	0	0

Special Requirements

- Special Requirement 1 0098025
- Special Requirement 2
- Special Requirement 3
- Special Requirement 4

Order Comments



Total List Price (W/O Freight & Warranty & Surcharges)	\$325,145
Marketing and Service Support Fee	\$1,395
Prepaid Freight	\$3,625
Total Surcharge/Options Not Subject To Discount	\$4,294
Total Weight (lbs)	19,115

Prices and Specifications Subject to Change Without Notice.

Unpublished options may require review/approval.
Dimensional and performance data for unpublished options may vary from that displayed in CRM.

PRICING DISCLAIMER

While we make every effort to maintain the web site to preserve pricing accuracy, prices are subject to change without notice. Although the information in this price list is presented in good faith and believed to be correct at the time of printing, we make no representations or warranties as to the completeness or accuracy of this information. We reserve the right to change, delete or otherwise modify the pricing information which is represented herein without any prior notice. We carefully check pricing specifications, but occasionally errors can occur, therefore we reserve the right to change such prices without notice. We disclaim all liability for any errors or omissions in the materials. In no event will we be responsible for any damages of any nature whatsoever from the reliance upon information from these materials. Please check your order prebills to confirm your pricing information



Shipping Destinations

Intermediate Destination: NONE

Final Destinations	Quantity
K860 - KENWORTH NORTHEAST GROUP - BOSTON 1150 WEST CHESTNUT ST. BROCKTON, Massachusetts 02301	1



Customer Quote

Equipment

Quantity:	1	
Truck Price:	\$325,145	
Dealer Options:	\$0	
Extended Warranty:	\$3,495	
Equipment Price:	\$240,851	
Surcharges Not Subject to Discount:	\$0	
Options Not Subject to Discount:	\$799	
Factory Freight Cost:	\$3,625	
Total Equipment Price:		<u>\$241,780</u>

NET Sale Price: **\$201,693**

Miscellaneous

FET Tire Credit:	\$0
Net Chassis FET:	\$24,107
State Tax:	\$0
Body/Trailer/Accessories FET:	\$0
Fees:	\$0
Other:	\$0

Quotation Total: **\$225,800**

This quotation worksheet is provided to aid dealers in their pricing efforts. Since PACCAR Inc and its truck divisions have no control over data input and various transactional circumstances that may affect the FET calculation, it is not to be considered tax advice. The dealer should consult his own tax advisor for the proper calculation of any taxes under the variety of circumstances, which may occur.

HORIZONTAL DIMENSIONS

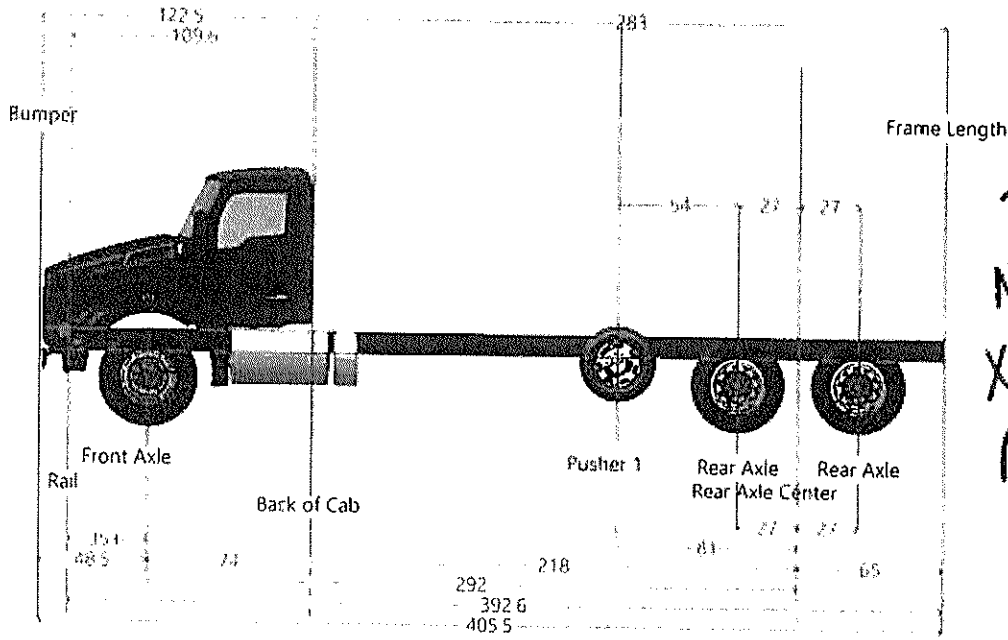

2026
 T880 AT
 NON LF chassis
 X15 525/1850 FFLS
 ALLISON 4500RWD Speed

Dimension	Measurement	Start	End
Axle Spacing	54	265	319
Bumper to Back of Cab	122.5	48.5	74
Bumper to Front Axle	48.5	48.5	0
Bumper to Front Frame	12.9	48.5	35.6
Cab to End of Frame	283.0	74	357
Cab to Rear Axle	218.0	74	292
Effective Bumper to Back Of Cab	122.5	48.5	74
Frame Length	392.6	35.6	357
Front Axle to Back of Cab	74.0	0	74
Front of Frame to Axle	35.6	35.6	0
Load Space	283.0	74	357
Overall Length	405.5	48.5	357
Overhang	65.0	292	357
Pusher Offset #1	-27.0	265	292
Pusher Offset #2	27.0	265	292
Pusher Offset #3	27.0	265	292
Tag Offset	27.0	292	319
Wheelbase	292	0	292

FRAME LAYOUT

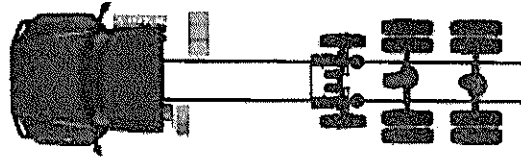

Note: Optional content may be displayed. The order has not yet received an engineering review. The actual arrangement of components may not be exactly as pictured. Additional changes may be made to the layout by Kerworth. Add a Custom Frame Layout code if an exact layout is required.

Selected Options [View more >>>](#)

Sales Code	Description	Length	Side
7210050	Fuel Tank 30 US Gal on 2 1/2 in. Aluminum Under	47 in	Left
7722153	Small Round DEF Tank 14 Gallons	10 in	Left
0106641	Battery Box Cast Iron Aluminum BCC 12.5V 65 Ah	75 in	Right

156 Epping Rd.
Exeter, NH 03833
(603)778-8158
www.netruckcenter.com

Date	Estimate #
12/10/2024	KWT880-GLV

Name / Address
New England Truck Center 156 Epping Road Exeter, NH 03833

OP#	PO #	Rep
KWT880-GLV	STOCK	

Item	Description	Qty	Total
Chassis	2025 KENWORTH T880 VIN# TBD FET INCLUDED	1	229,896.00
Bodies	2025 NRC 40TB-28' SERIAL# TBD	1	71,145.00
FET Payable	BODY FET	1	10,712.58
C-NC21	40 000 TB	1	0.00
C-4028	28' - 40 000 TB	1	0.00
C-NC46	COMPLETE EQUIPMENT	1	0.00
C-D415	5 CHAIN SLOTS PER SIDE (18 TOTAL FOR 25', 26', 27', 28', 29', 30')	1	0.00
C-D44-4	SINGLE ROW OF (4) EXTRA CHAIN SLOTS IN THE CENTER OF DECK	1	0.00
C-DO	1/4" STEEL CHECKER PLATE (STANDARD FOR 40 000-TB)	1	0.00
C-C3	FLAT TOP DECK WITH STAKE POCKET, WITHOUT REMOVABLE RAILS	1	0.00
C-B3S	3" HIGH X 9" SPACING (STANDARD FOR 30 000-TB AND 40 000-TB)	1	0.00
C-L16	5 MARKER LIGHTS PER SIDE	1	0.00
C-T04-1	DP 20,000 LBS WITH 5/8" X 75' WIRE ROPE(STANDARD FOR 40 000-TB)	1	0.00
C-NC156	WINCH AIR FREE SPOOL ON LEFT HAND SIDE (NC)	1	0.00
C-NC30	75' STEEL WIRE ROPE	1	0.00
C-CR01	SWIVEL HOOK	1	0.00
C-CTR01	EXTRA FOR TRI-AXLE BODY	1	0.00
C-NC172	PAIR W/ ANOTHER KIT FOR SHIPPING TO DEALER ON A FLAT DECK TRAILER WITHIN NORTH AMERICA.FREIGHT NOT INCLUDED. FCA NRC FACTORY.	1	0.00
C-12V	12V WIRING	1	0.00
C-E51	HEAVY DUTY TOW BAR T-BAR 4" X 4" (STD)	1	0.00
C-G20	GALVANIZED SUB-FRAME AND BUMPER	1	0.00
C-NC17	CLEAR MARKER LIGHT	1	0.00
C-L118	8 X 4 1/2" LIGHT (6 RED (STOP-FLASH) / 2 BACKUPS) - ON BUMPER	1	0.00
		Total	

156 Epping Rd.
Exeter, NH 03833
(603)778-8158
www.netruckcenter.com

Date	Estimate #
12/10/2024	KWT880-GLV

Name / Address
New England Truck Center 156 Epping Road Exeter, NH 03833

OP#	PO #	Rep
KWT880-GLV	STOCK	

Item	Description	Qty	Total
C-NC11	LEVER CONTROL STANDARDS	1	0.00
C-S052	STAINLESS ON REAR BUMPER	1	0.00
C-G012	STABILIZER GRIP (30,000 & 40,000 LBS) (4X4)	1	0.00
C-L112-1	2 LED WORK LIGHTS ON TOP OF THE REAR BUMPER	1	0.00
C-A432	TRAILER HITCH & PINTLE HOOK ADAPTOR (4 HOLES) (T-BAR 4X4)	1	0.00
C-A1	STANDARD CHAIN RACK	1	0.00
C-A12	STD WINCH EMBEDDED IN CHAIN RACK	1	0.00
C-L118	8 X 4 1/2" LIGHT (6 RED (STOP-FLASH) / 2 BACKUPS) - ON CHAIN RACK	1	0.00
C-NC40	CHAIN RACK NRC BLACK PAINT	1	0.00
C-S093	STAINLESS ON SIDES AND HEAD OF CHAIN RACK	1	0.00
C-L112-1	2 LED WORK LIGHTS UNDER THE TOP OF THE CHAIN RACK	1	0.00
C-LO6P	WIRELESS REMOTE CONTROL LODAR 6 BUTTONS	1	0.00
C-A421	RECOVERY ROLLER GUIDE (ROLLBACK)	1	0.00
C-S056	STAINLESS ON OIL TANK	1	0.00
C-NC110	WIRED TOWLIGHT ONLY	1	0.00
C-T6	TOUCHPAD WITH FUSELESS LIGHTING SYSTEM CONTROLLER	1	0.00
C-P-O	NO NEW CUSTOM REQUEST	1	0.00
C-DISCLAIMER	CUSTOMER, FINAL PURCHASER OR END USER HAS BEEN INFORMED OF THE RISKS AND BENEFITS OF HOT DIP GALVANIZING (HDG) OF HIS NRC CAR CARRIER DECK	1	0.00
C-NC26	"BLACK POLYMER CONTROL BOXES (STANDARD)	1	0.00
C-RACK6	74" (1880MM) - HEIGHT ABOVE FRAME RAILS (C#6)	1	0.00
C-PGAL-2	DECK GALVANIZED (OPTION FOR 24'-30' DECKS) UNCONFIGURABLE ITEMS	1	0.00
DESTTRANSPORT	DESTINATION TRANSPORT CHARGE	1	1,300.00
30/40TBINSTALL-IN...	DEALER INSTALL WITH PTO, HOSE TRACK, STANDARD STOCK PAINT AND DETAIL	1	11,500.00
		Total	

156 Epping Rd.
Exeter, NH 03833
(603)778-8158
www.netruckcenter.com

Date	Estimate #
12/10/2024	KWT880-GLV

Name / Address
New England Truck Center 156 Epping Road Exeter, NH 03833

OP#	PO #	Rep
KWT880-GLV	STOCK	

Item	Description	Qty	Total
72AMBJUSTLB-INST	72" AMBER JUSTICE LIGHT BAR INSTALLED	1	2,450.00
MX701818.KM-INST	70" RC TOOLBOX, ALUMINIUM BOX, STAINLESS STEEL DOOR INSTALLED	2	4,176.52
PRICING BASED OFF OF CURRENT PRICING, SUBJECT TO CHANGE CLOSER TO BUILD DATE			
Total			\$331,180.10

ONCE THE BUYER ACCEPTS THIS ORDER, THE BUYER'S DEPOSIT IS NOT REFUNDABLE UNLESS THE BUYER CANNOT TAKE DELIVERY OF SAID VEHICLE(S) FOR A REASON BEYOND THE BUYER'S CONROL. IN THAT EVENT, THE DEALER MAY, BUT WILL NOT BE REQUIRED TO, RETURN THE DEPOSIT TO THE BUYER, LESS ANY EXPENSES WHICH THE DEALER HAS INCURRED IN ACCEPTING AND PROCESSING THIS ORDER. THE BUYER'S FAILURE TO OBTAIN FINANCING BEFORE SCHEDULED DELIVERY IS NOT A REASON BEYOND THE BUYER'S CONTROL. THE BUYER WILL ALSO BE SUBJECT TO ANY PRICE INCREASES THAT ARE RECEIVED BY THE DEALER PERTAINING TO THE CHASSIS OR BODY. BY SIGNING THIS THE BUYER ACKNOWLEDGES HAVING READ AND AGREEING TO THESE TERMS AND CONDITIONS.

Signature _____



Terms & Conditions

- Once the buyer accepts this order, the buyer's deposit is not refundable unless the buyer cannot take delivery of the said vehicle(s) for a reason beyond the buyer's control. In that event, the dealer may, but will not be required to return the deposit to the buyer, less any expenses which the dealer has incurred in accepting and processing this order. The buyer's failure to obtain financing before scheduled delivery is not a reason beyond the buyer's control.
- The buyer will be subject to any price increase and or surcharge that are received by the dealer pertaining to the chassis or body.
- The buyer will be subject to any price increase on raw materials / parts that are incurred from the time of placing the order to the actual time of build and delivery of the unit(s).
- By signing this the buyer acknowledges having read and agreeing to these terms and conditions.

Date: _____

Signature of Purchaser: _____

Opp# _____ Chassis: _____ Body: _____

NETC Representative: _____

"Everything Truck"

156 Epping Road Exeter NH 03833 +1 603 778 8158

www.NEtruckcenter.com