



156 Epping Road Exeter, NH 03833

800-261-7219

Stock Number: #STOCK PB 536

2026 Peterbilt 536

Details:

- 2025 NRC 20TB - 22'
- Fully Galvanized Deck and Subframe
- Lodar Remote
- 10k Winch
- Paccar PX-7
- 300HP
- Allison 2500 RDS
- Full Chassis / Body spec attached

Price: 185,501



New England Truck Center
 156 Epping Road
 Exeter, New Hampshire 03833
 United States of America

MIKE LAMPERT

Vehicle Summary

		Unit		Chassis	
Model:		Model 536	Fr Axle Load (lbs):		10000
Type:		Full Truck	Rr Axle Load (lbs):		20000
Description 1:		NETC STOCK 536	G.C.W. (lbs):		26000
Description 2:		Clone of Chassis 728285 Model 536			
		Application	Road Conditions:		
Intended Serv.:		City Delivery	Class A (Highway)		100
Commodity:		Other Commodity	Class B (Hwy/Mtn)		0
			Class C (Off-Hwy)		0
			Class D (Off-Road)		0
		Body	Maximum Grade:		6
Type:		Van	Wheelbase (in):		230
Length (ft):		24	Overhang (in):		69
Height (ft):		13.5	Fr Axle to BOC (in):		67.5
Max Laden Weight (lbs):		1000			
			Cab to Axle (in):		162.5
			Cab to EOF (in):		231.5
			Overall Comb. Length (in):		339
		Trailer			
No. of Trailer Axles:		0			
Type:					
Length (ft):		0			
Height (ft):		0			
Kingpin Inset (in):		0			
Comer Radius (in):		0			
		Restrictions			
Length (ft):		40			
Width (in):		102			
Height (ft):		13.5			

Special Req.

Approved by: _____

Date: _____

Note: All sales are F.O.B. designated plant of manufacture.

Sales Code	Std/Opt	Description	\$ List	Weight
Base Model				
0005361	S	Model 536 The Model 536 is the ultimate Class 6 medium duty. It is highly adaptable and can be configured up to 26,000 lbs. to meet the demands of a variety of medium-duty applications. Combining durability and power with options to match the needs of both the job and driver, the 536 is an exceptional performer and ideal for refrigerated van, pickup and delivery, wrecker and municipal utility applications.	106,244	9,470
0091200	S	Other Commodity	0	0
0093340	S	City Delivery Truck or tractor which hauls freight, typically operating within a 100-mile radius, on public streets and highways and other paved surfaces. Typically includes package and freight delivery.	0	0
0095040	S	Van	0	0
0098170	S	United States Registry Canadian Registry Package Requires Air Conditioning Excise Tax Canada, Speedometer to be KPH ipo MPH, Daytime Running Lights and Rubber Battery Pad in Bottom of Battery Box.	0	0
Configuration				
0200700	S	Not Applicable Secondary Manufacturer	0	0
0210260	S	Class 6 Chassis Weight Rating 26,000 lb GVWR	0	0
Frame & Equipment				
0515010	O	10-5/8" Steel Rails 326-384" 10.625 x 3.45 x .313 Dimension, 1,776,000 RBM; Yield Strength: 120,000 psi. Section Modulus: 14.8 cubic inches. Weight: 1.44 lbs/inch pair	663	442
0611300	O	Heavy Duty 5-Piece Crossmember BOC IPO Standard Class 5, 6, 7	46	20
0611330	O	Zinc Coated Anti Corrosion Treated Frame Rails Requires Frame Rail Code. Zinc Phosphate coating will replace the standard frame rail primer and provide added corrosion prevention for your customer's operating in severe conditions or in climates where vehicle rust is common.	364	2
0611790	O	Aluminum Frame Rail Crossmembers Excludes suspension	178	-7
0612230	O	Custom Wheelbase or Overhang Engineering approval may be required.	350	0
0644090	S	EOF Square without Crossmember End-of-frame square without crossmember. For use with body builder installed crossmember.	0	0
0651090	S	Omit Rear Mudflaps and Hangers	0	0
Front Axle & Equipment				

Price Level: January 1, 2024

Deal: NETC STOCK 536

Printed On: 9/13/2024 7:31:25 AM

Date: September 13, 2024

Quote Number: QUO-1129115-Z7T9N6

Sales Code	Std/Opt	Description	\$ List	Weight
1011830	O	Dana Spicer E1002IL 10,000 lb, 3.5 in. Drop Axle is designed for applications with a gross axle weight rating (GAWR) of 10,000 pounds. The axles have exclusive one-piece forged design knuckle including steer arm, tie rod arm and spindle. This feature helps in greater durability and reduced maintenance.	251	0
1111155	S	Mono-Leaf Springs, Shocks, 10,000 LBS.	0	0
1243040	S	Power Steering Sheppard HD94 Sheppard HD94 power steering gear is a light weight version of heavy duty line-haul power steering gear. For use with 10,000 to 13,200 lb. axle ratings.	0	0
1250180	O	Power Steering Reservoir Frame Mounted The power steering reservoir is a steering system that eases drivability by applying hydraulic pressure to the steering gear.	0	0
1353540	O	PHP10 Aluminum PreSet PLUS Hubs PHP10 aluminum PreSet PLUS hubs have a fully integrated spindle nut design, an optimized wheel spacer, magnetic fill plug on drive and trailer hubs for inspection of metal particles in lubricant, with a long life oil seal and bearings are pre-adjusted. Use with Front Axle.	47	-18
1380240	O	Dana Spicer Wide Track IPO Standard Dana Spicer wide track front axles offer added stability and deliver greater turn angles. 71in KPI IPO 69in for E1202, E1322, E1462, D2000F front axles.	56	15
1380260	O	Bendix Air Cam Front Drum Brakes 16.5x5 For use with 10,000 lbs to 14,600 lbs steer axles. Includes automatic slack adjusters & outboard mounted brake drums.	0	0
1390540	O	Dust Shields, Cam Brakes, Front Axle	51	4
1391410	O	Gusseted Cam Brackets, Steer Axle	0	0
1391470	U	5 MM FRONT SPRING SPACER BLOCKS	0	0
Rear Axle & Equipment				
1513260	O	Dana Spicer P20060S 20,000 lb	1,403	-97
1616290	O	PHP10 Aluminum PreSet PLUS Hubs	76	0
1660000	O	Dust Shields For Cam Brakes, Drive Axle(s)	61	15
1680490	O	Gusseted Cam Brackets, Drive Axle(s)	30	2
1680500	S	SBM Valve Full trucks require a spring brake modulation (SBM) system for emergency braking application. This system requires an SBM valve and a relay valve with spring brakes on the rear axles. The SBM valve allows the foot valve to operate the rear axle spring brakes if a failure exists in the rear air system.	0	0
1680795	O	Diff Lock, Single Drive Axle with Speed Interlock	1,732	30

Price Level: January 1, 2024
Deal: NETC STOCK 536
Printed On: 9/13/2024 7:31:25 AM

Date: September 13, 2024
Quote Number: QUO-1129115-Z7T9N6

Sales Code	Std/Opt	Description	\$ List	Weight
1680950	S	Stability System Not Selected Or Not Available	0	0
1682430	S	Anti-Lock Braking System (ABS) 4S4M ABS-6. Includes air braking system.	0	0
1684200	S	Synthetic Axle Lubricant All Axles Peterbilt heavy duty models include Fuel Efficient Cognis EMGARD FE75W-90 which provides customers performance advantages over current synthetic lubricants with reduced gear wear and extended maintenance intervals, resulting in increased uptime. In addition, the lubricant provides improved fluid flow to protect gears in extreme cold conditions and withstand the stress from high temperatures, extending component life.	0	0
1687010	S	Bendix Air Cam Rear Drum Brakes 16.5x7 Bendix Air Cam Rear Drum Brakes to fit all heavy haul, construction, refuse and highway truck and tractor applications. Includes Automatic Slack Adjusters & Outboard Mounted Brake Drums.	0	0
1704630	O	Ratio 4.63 Rear Axle	0	0
1811140	O	Peterbilt Low Air Leaf 21,000 lb, Light Weight	378	-175
1922260	O	Dash Mtd Dump Switch with Indicator Light Dash mounted dump switch with indicator light for suspension.	31	2
Engine & Equipment				
2073513	O	PACCAR PX-7 300@2600 GOV@2600 660@1600 Performance (2024 Emissions)	2,329	0
		N21350 C121 64....Maximum Accelerator Pedal Ve		
		N21370 C128 64....Maximum Cruise Speed (P059)		
		N21460 C132 1400..Max PTO Speed (P046)		
		N21520 C133 5.....Timer Setting (P030)		
		N21610 C188 39....Low Ambient Temperature Thre		
		N21620 C189 60....Intermediate Ambient Tempera		
		N21630 C190 80....High Ambient Temperature Thr		
		N21550 C206 35....Engine Load Threshold (P516)		
		N21340 C209 120...Hard Maximum Speed Limit (P1		
		N21510 C225 YES...Enable Idle Shutdown Park Br		
		N21450 C231 NO....Gear Down Protection (P026)		
		N21570 C233 NO....Idle Shutdown Manual Overrul		
		N21440 C234 NO....Engine Protection Shutdown (
		N21480 C238 NO....Auto Engine Brake in Cruise		
		N21470 C239 NO....Cruise Control Auto Resume (
		N21430 C333 0.....Reserve Speed Limit Offset (
		N21410 C334 0.....Maximum Cycle Distance (N202		
		N21590 C382 YES...Enable Hot Ambient Automatic		
		N21500 C395 0.....Expiration Distance (N209)		
		N21530 C396 YES...Enable Impending Shutdown Wa		
		N21540 C397 60....Timer For Impending Shutdown		
		N21320 C399 120...Standard Maximum Speed Limit		
		N21400 C400 252...Reserve Speed Function Reset		

Price Level: January 1, 2024

Deal NETC STOCK 536

Printed On: 9/13/2024 7:31:25 AM

Date: September 13, 2024

Quote Number: QUO-1129115-Z7T9N6

Sales Code	Std/Opt	Description	\$ List	Weight
		N21420 C401 10....Maximum Active Distance (N20 N21330 C402 0.....Expiration Distance (N207)		
2091120	S	EMUX Electronics Architecture	0	0
2091305	O	Engine Idle Shutdown Timer Enabled	0	0
2091315	O	Enable EIST Ambient Temp Override	0	0
2091372		Eff EIST NA Expiration Miles	0	0
2091640		Effective VSL Setting NA	0	0
2092015	O	Typical Operating Speed 70 MPH	0	0
2092031	S	Powertrain Optimized for Fuel Economy Best analysis for vehicles which operate at or near cruise speed 90 plus percent of time.	0	0
2140200	O	CARB Engine Idling Compliance PACCAR PX-7, PX-9 and MX, Cummins X15 and ISX diesel engines will include the required factory installed serialized sticker on the drivers door to identify them as meeting the NOx idling standard.	0	0
2140460	O	Remote PTO/Throttle, 12-Pin, 250K BOC/BOS J1939, Remote Control Provision	212	0
2140660	O	CARB Emission Warranty	0	0
2140700	S	EPA Engine Idling Compliance	0	0
2513060	S	PACCAR 160 Amp Alternator, Brushed PACCAR 160 AMP alternator, brushed producing 160 Amps at road speed and 100 Amps at idle.	0	0
2521090	O	Immersion Type Block Heater 110-120V Standard location is left-hand under cab, Model 520 is in bumper, and for Model 220 it is at the driver step. Plug includes a weather-proof cover that protects the receptacle. This pre-heater keeps the coolant in the engine block from freezing when the engine is not running.	105	2
2522160	S	PACCAR 12V Starter PX-7 Engine Only	0	0
2538030	S	2 PACCAR Premium 12V Starting Batteries 2000 CCA Threaded stud type terminal. Stranded copper battery cables are double aught (00) or larger to reduce resistance.	0	0
2539720	O	Low Voltage Disconnect System	0	0
2621090	S	HORTON ON/OFF Fan Clutch Horton DM Advantage Two-Speed Fan Clutch On/Off for heavy-duty, medium-duty and a variety of off-highway equipment.	0	0
2723210	S	18.7 CFM Air Compressor N/A X15. Furnished on engine. Teflon lined stainless steel braided compressor discharge line.	0	0

Price Level: January 1, 2024

Deal: NETC STOCK 536

Printed on: 9/13/2024 7:31:25 AM

Date: September 13, 2024

Quote Number: QUO-1129115-Z7T9N6

Sales Code	Std/ Opt	Description	\$ List	Weight
2812210	S	VGT Exhaust Brake (Variable Geometry Turbo). Provides approximately 90-100 HP of retardation and is part of the turbocharger.	0	0
2921110	S	PACCAR Fuel/Water Separator Standard Service PACCAR Fuel/Water separator standard service intervals. High efficiency media protects critical engine components.	0	0
2921210	S	No Fluid Heat Option for Fuel Filter	0	0
2921320	O	12V Heat for Fuel Filter Fuel filter heaters help ensure a seamless flow of diesel from the tank to the combustion chamber. Eliminating any possibility of moisture freezing within the fuel filter while simultaneously increasing the fuel temperature for atomization within the engine.	62	0
3114270	S	High Efficiency Cooling System Cooling module is a combination of steel and aluminum components, with aluminum connections to maximize performance and cooling capability. Silicone radiator & heater hoses enhance value, durability, & reliability. Constant tension band clamps reduce leaks. Chevron Delo Extended Life Coolant (NOAT) extends maintenance intervals reducing maintenance costs. Anti-freeze effective to -30 degrees F helps protect the engine. Low coolant level sensor warns of low coolant condition to prevent engine damage. Radiator Size by Model: 520 1202 sq in, 579 1456.9 sq in, 535/536/537/548 949.3 sq in, 537/548 VOC 1000.3 sq in, 389 HH 1604 sq in, 567 1379 sq in.	0	0
3211140	S	(1) Air Cleaner Engine Mounted	0	0
3367180	S	Exhaust Single RH Horizontal DPF/SCR RH Under Frame, Single Module	0	0
Transmission & Equipment				
4052910	O	Allison 2500 RDS-P Transmission, Gen 6 Rugged Duty Series	3,758	-198
4210940	O	SPL100 Driveline, 2 Midship Bearings	1,555	60
4230080	O	PTO F/O Chelsea	0	0
4233510	O	Park Brake Interlock For use with transmission mounted PTO	73	2
4233910	O	(1) Dash Mounted Single Acting EOH PTO Control Electric-over-hydraulic, spec'ing PTO switch does not ensure the PTO will fit. Sends signal to Allison to engage PTO.	107	1
4250350	U	Allison HS, EVS, RDS, Pkg 354	0	0
4252170	O	Auto Neutral Activates With Parking Brake Auto Neutral helps improve jobsite safety by reducing the possibility of the truck moving due to throttle application.	16	0
4252890	O	Allison FuelSense Not Desired Dynamic Shift Sensing	0	0
4252940	O	Allison Neutral At Stop	0	0

Price Level: January 1, 2024

Deal: NETC STOCK 536

Printed On: 9/13/2024 7:31:25 AM

Date: September 13, 2024

Quote Number: QUO-1129115-Z7T9N6

Sales Code	Std/Opt	Description	\$ List	Weight
		Neutral at Stop features and benefits: Reduces or eliminates the load on the engine when vehicle is stopped, can help lower fuel consumption and CO2 emissions, and is included in FuelSense 2.0 Plus and Max packages only.		
4256880	O	Allison 6-Speed Configuration Wide ratio gears, 2500 series transmissions.	0	0
4256920	O	Dash Mounted Push Button Shifter Available with Allison transmissions	592	3
4257110	O	LH Mounted Trans PTO Provisions	37	0
Air & Trailer Equipment				
4510190	S	Bendix AD-HF Air Dryer, Heater Bendix AD-HF air filters protects the life of your engine system and components. Proven PuraGuard oil coalescing technology in the the air dryer cartridge. This oil coalescing filter ensures the removal of oil and oil aerosols before they can contaminate the moisture removing desiccant.	0	0
4520420	O	Pull Cords All Air Tanks	5	0
4540420	S	Nylon Chassis Hose	0	0
4543320	S	Steel Painted Air Tanks All air tanks are steel with painted finish except when Code 4543330 Polish Aluminum Air Tanks is also selected (then exposed air tanks outside the frame rails will be polished aluminum). Peterbilt will determine the optimal size and location of required air tanks. Narratives requesting a specific air tank size or location will not be accepted for factory installation. See ECAT to determine number or location of air tanks installed.	0	0
Tires & Wheels				
5007340	O	FF: CN 16ply 255/70R22.5 HSR2 SA	23	-46
5107420	O	RR: CN 16ply 255/70R22.5 HDR Efficiency Rating: Fair	412	-68
5190004	O	Code-rear Tire Qty 04	0	0
5220770	O	FF: Alcoa ULA187 22.5X8.25 High Polish Alum Ultra One wheel with MagnaForce alloy.	425	-50
5320770	O	RR: Alcoa ULA187 22.5X8.25 High Polish Alum Ultra One wheel with MagnaForce alloy.	850	-100
5390004	O	Code-rear Rim Qty 04	0	0
5407640	O	FF: Mirror Polish Wheels, Outer Surface Single/tandem steer. Mirror Polish outer surface of outer wheel. Without chrome wheel nuts.	66	0

Sales Code	Std/ Opt	Description	\$ List	Weight
5407650	O	RR: Mirror Polish Wheels, Outer Surface, Single Drive without chrome wheel nuts. Mirror polish outer surface of outer wheel.	253	0
5410140	O	FF: Dura-Bright Finish Outer Surface of Outer Wheel, requires Polished Option	234	0
5410150	O	RR: Dura-Bright Finish-Single Axle Outer Surface of Outer Wheel, requires Polished Option.	234	0
Fuel Tanks				
5584100	O	D-Shaped Aluminum 70 Gallon Fuel Tank LH U/C Non-slip step LH under cab	348	0
5602070	O	Location LH U/C 70 Gallon	0	0
5650540	O	Polish (1) Non-Slip Fuel Tank Step, U/C Tank Only	30	0
5650810	O	Polish (1) Aluminum Fuel Tank	201	0
5652830	O	Polish All Fuel / Hydraulic Tank Straps Does not apply to rectangular DEF tank straps	12	0
5652890	S	DEF Tank Mounted LH BOC Models 220 and 520 mounted left hand back-of-cab.	0	0
5652980	S	DEF To Fuel Ratio Between 1:1 And 2:1	0	0
5653000	O	Polished Stainless Steel Cover For DEF Tank	194	0
5655019	S	DEF Tank Small, HD 14 Gal 2.1M MD 5.5 Gal	0	0
Battery Box & Bumper				
6020040	O	MD Battery Box, Non-Slip Step RH Under Cab	196	0
6030150	O	Rubber Battery Pad In Bottom of (1) Battery Box Mat in box that holds batteries only	13	4
6030540	O	Polish Battery/Tool Box(s) Aftertreatment Cab Entry, complete	459	0
6030630	O	Aluminum Battery Box Cover	184	4
6121020	O	Aero Bumper, Steel 3-Piece, Bright Finish ***Warning*** Due to a new legal regulations, all New Medium Duty trucks require headlights to be located in the bumper when the chassis height is GREATER than the following chassis height: Measurement to bottom of frame at front of frame: for the 107 Aero Hood 32.6, for the 109 Aero Hood 31.4, for the 109 Vocational Hood 26.7. Work with applications if your chassis height is unacceptable.	1,238	20
Cab & Equipment				
6510180	S	Peterbilt Aerodynamic 107in BBC SMC Hood With molded charcoal crown and aluminum cab.	0	0

Price Level: January 1, 2024

Deal: NETC STOCK 536

Printed On: 9/13/2024 7:31:25 AM

Date: September 13, 2024

Quote Number: QUO-1129115-Z7T9N6

Sales Code	Std/ Opt	Description	\$ List	Weight
6540160	O	Thermal Insulation Package in Cab The thermal insulation package is designed to make the cab thermally efficient in extreme temperatures. The model 520 adds insulation surrounding the doghouse to reduce engine heat transmitted to the cab.	68	2
6800180	O	Hood Crown - Bright Finish ipo Molded Gray	89	0
6914180	S	Sears Driver Seat	0	0
6924200	S	Sears (2) Person Passenger Seat	0	0
6930500	O	Drivers Armrest - RH Only	28	2
6930800	O	Black Seat Color IPO Standard Color	0	0
6939110	S	Toolbox Under Passenger Seat Non-Suspension Seat	0	0
6939400	S	Air Ride Driver	0	0
6939420	O	High Back Driver	40	0
6939470	S	Vinyl Driver	0	0
6939510	S	Non-Air Ride Passenger	0	0
6939540	S	Low Back Passenger	0	0
6939570	S	Vinyl Passenger	0	0
7000025	O	Steering Wheel With Multi-Function Includes Peterbilt logo on horn button , audio volume, seek, mute and mode button on LH pod with cruise control on/off/cancel, set/resume and accelerate/coast on the right pod.	239	4
7001520	S	Adjustable Steering Column - Tilt/Telescope	0	0
7036130	O	Probilt Interior Charcoal Gray - Curved Roof	170	0
7110680	O	Exterior Cab Entry Grabhandle Textured; NFPA compliant. Available on Day Cab specifications only.	179	0
7210420	O	Dark Window Tint IPO Standard Tint - Day Cab	22	0
7210540	S	Day Cab Rear Window Day cab rear window flush to back of cab.	0	0
7210550	S	1-Piece Glass Rear Cab Window Fixed	0	0
7230060	S	1-Piece Curved Windshield	0	0
7230360	S	Power Door Locks and Power Window Lifts Standard	0	0

Price Level: January 1, 2024
Deal: NETC STOCK 536
Printed On: 9/13/2024 7:31:25 AM

Date: September 13, 2024
Quote Number: QUO-1129115-Z7T9N6

Sales Code	Std/Opt	Description	\$ List	Weight
7322010	S	Combo Fresh Air Heater/Air Conditioner With radiator mounted condenser, dedicated side window defrosters, Bi-Level Heater/Defroster Controls, 54,500 BTU/HR, and silicone heater hoses.	0	0
7410040	O	Outside Sunvisor - Stainless Steel Not available with 2.1M high roof sleeper.	866	4
7510060	O	Aero Rear View Mirror Housing, Bright Finish	171	3
7514010	O	Peterbilt Aero Rear View Mirror, Motorized Includes top mirror with motorized, adjustable dual axis heated glass. Bottom mirror is an integrated convex surface. Includes black textured arms with breakaway feature.	336	3
7514050	S	Look Down Mirror Over Passenger Door with Black Housing	0	0
7610500	O	Air Horn Mounted Under Cab	82	8
7721060	O	7" Infotainment Display Incl Apple Carplay	1,460	7
7725710	O	Standard Speaker Package For Cab (2) Speakers	51	4
7788335	O	Global Telematics Hardware	0	0
7851480	S	Peterbilt Electric Windshield Wipers With Intermittent Feature.	0	0
7852050	O	Auto Reset Circuit Protection Daycab and Sleeper	19	0
7852060	S	Solid Rear Day Cab Mounts	0	0
7900090	O	Triangle Reflector Kit, Ship Loose Florescent triangle emergency road flares are designed to meet and exceed all DOT standards.	33	13
7900310	O	Fire Extinguisher, Mounted Outboard Driver Seat Hazmat approval UL listed/rated ABC	64	9
7901140	O	Backup Alarm (87-112 DB) Variable adjusting	44	6
8011850	O	Transmission Oil Temperature (Main) Located in Digital Cluster Display.	30	0
8021380	S	Air Restriction Indicator Mounted on air cleaner, intake piping, or firewall	0	0
8041200	O	Dual Scale Speedometer MPH Over KPH	0	0
8070110	O	(5) Additional Dash Switches with Wiring Located on dash panel C. Availability subject to dash space. Includes 4" 14 gauge wire with butt splice at rear of each additional switch.	253	2
8070390	O	Engine Hourmeter Gauge Located in Digital Cluster Display	0	0
8070450	O	Engine PTO Hourmeter Gauge Located In Digital Cluster Display	0	0

Price Level: January 1, 2024

Deal: NETC STOCK 536

Printed On: 9/13/2024 7:31:25 AM

Date: September 13, 2024

Quote Number: QUO-1129115-Z7T9N6

Sales Code	Std/Opt	Description	\$ List	Weight
8070810	O	Engine Manifold Pressure (Turbo Boost) Located in Digital Cluster Display	0	0
8070860	S	Main Instrumentation Panel Digital Cluster 7" Display includes: Physical (Analog) - Speedometer, Tachometer, Oil Pressure, Coolant Temp and Display Gauges - Fuel Level, DEF Level, DPF Filter Status, Fuel Economy, Volts Telltale, OAT and Primary Air Pressure, Secondary Air Pressure for air brake trucks.	0	0
8070940	O	Voltmeter Gauge (MD/520 Only) Located in Digital Cluster Display	0	0
8111110	S	Headlights Composite Fender Mounted Integral DRL/Park, Turn, and Side Marker	0	0
8121210	O	(5) Marker Lights, Chrome Housing Aero LED	63	0
8131560	O	(2) Peterbilt Fog Lights Recessed in Bumper	248	6
8133470	O	Switch & Wiring for F/O Beacon/Strobe Switch and wiring for furnished by owner beacon / strobe, 10' coiled wire back-of-cab / back-of-sleeper, at rear sill.	89	2
8134160	S	Self-Canceling Turn Signal	0	0
8140120	O	Incandescent Square Stop/Turn/Tail/Backup Left-hand / right-hand square end of frame or dropped a-brace	26	9

Paint

8530770	S	(1) Color Axalta Two Stage - Cab/Hood Base Coat/Clear Coat N85020 A - L0001EY BLACK N85500 CAB ROOF L0001EY BLACK N85300 FENDER L0001EY BLACK N85200 FRAME L0001EA BLACK N85400 HOOD TOP L0001EY BLACK	0	0
---------	---	---	---	---

Shipping Destination

Options Not Subject To Discount

9400091	S	Peterbilt Class 7 Standard Coverage 1 year/Unlimited Miles/km	0	0
9400093	S	PACCAR PX-7 Standard Coverage 3 years/Unlimited Miles/Unlimited hrs	0	0
9408634	O	SmartLINQ RD - 5YR Sub PACCAR PX Engines	799	0
9408702	O	Base Warr: Emissions (CARB Operation) 5YR/150K MI - PX-7 Engine	1,224	0
9408931	O	PDI At Excellence Peterbilt Location	230	0
9408936	O	Frame Layout Identical to Previous Chassis	550	0

Price Level: January 1, 2024
Deal: NETC STOCK 536
Printed On: 9/13/2024 7:31:25 AM

Date: September 13, 2024
Quote Number: QUO-1129115-Z7T9N6

Sales Code	Std/ Opt	Description	\$ List	Weight
Miscellaneous				
9409041	S	Aero Hood (MODEL 536)	0	0
9409079	O	State Of Registry: New Hampshire	0	0
9409749	O	2024 Series Emissions Engine	0	0

Promotions

Special Requirements

- Special Requirement 1 0098170
- Special Requirement 2
- Special Requirement 3
- Special Requirement 4

Order Comments

Total List Price (W/O Freight & Warranty & Surcharges)	\$130,854
Marketing and Service Support Fee	\$870
Prepaid Freight	\$3,525
Total Surcharge/Options Not Subject To Discount	\$2,803
Total Weight (lbs)	9,423

Prices and Specifications Subject to Change Without Notice.

Unpublished options may require review/approval.
Dimensional and performance data for unpublished options may vary from that displayed in CRM.

PRICING DISCLAIMER

While we make every effort to maintain the web site to preserve pricing accuracy, prices are subject to change without notice. Although the information in this price list is presented in good faith and believed to be correct at the time of printing, we make no representations or warranties as to the completeness or accuracy of this information. We reserve the right to change, delete or otherwise modify the pricing information which is represented herein without any prior notice. We carefully check pricing specifications, but occasionally errors can occur, therefore we reserve the right to change such prices without notice. We disclaim all liability for any errors or omissions in the materials. In no event will we be responsible for any damages of any nature whatsoever from the reliance upon information from these materials. Please check your order prebills to confirm your pricing information

Shipping Destinations

Intermediate Destination: PDI At Excellence

Final Destinations	Quantity
---------------------------	-----------------

HORIZONTAL DIMENSIONS

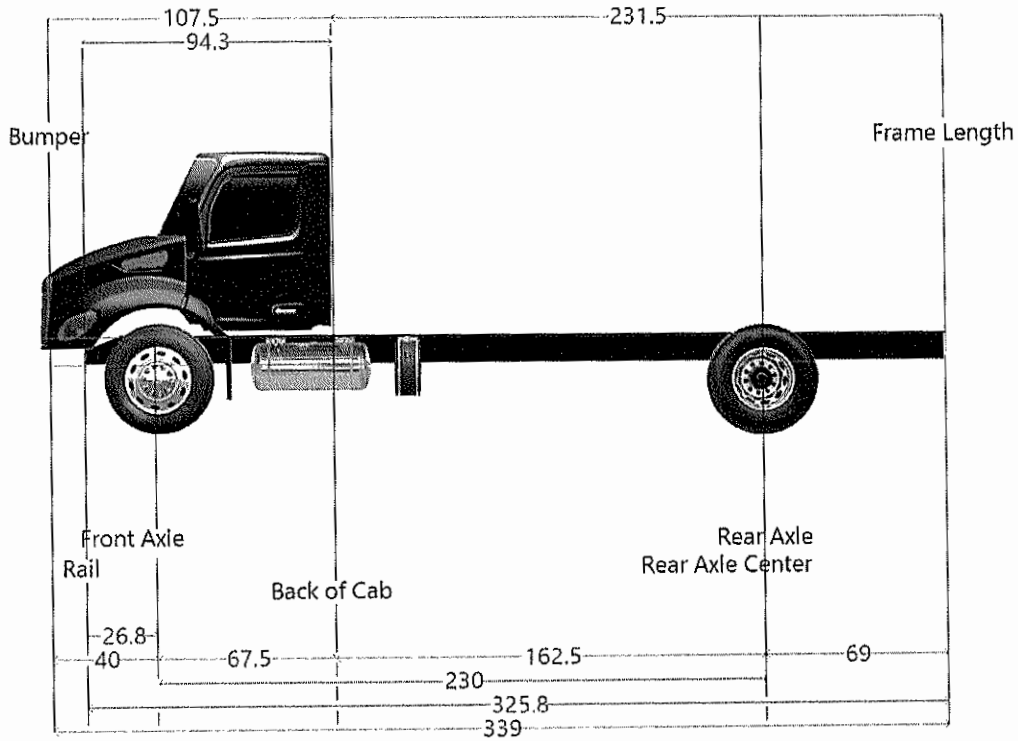

Dimension	Measurement	Start	End
Axle Spacing	0	230	230
Bumper to Back of Cab	107.5	-40	67.5
Bumper to Front Axle	40	-40	0
Bumper to Front Frame	13.2	-40	-26.8
Cab to End of Frame	231.5	67.5	299
Cab to Rear Axle	162.5	67.5	230
Effective Bumper to Back Of Cab	107.5	-40	67.5
Frame Length	325.8	-26.8	299
Front Axle to Back of Cab	67.5	0	67.5
Front of Frame to Axle	26.8	-26.8	0
Load Space	231.5	67.5	299
Overall Length	339	-40	299
Overhang	69	230	299
Pusher Offset #1	0	230	230
Pusher Offset #2	0	230	230
Pusher Offset #3	0	230	230
Tag Offset	0	230	230
Wheelbase	230	0	230

156 Epping Rd.
Exeter, NH 03833
(603)778-8158
www.netruckcenter.com

Date	Estimate #
12/10/2024	PB53620TB

Name / Address
New England Truck Center 156 Epping Road Exeter, NH 03833

OP#	PO #	Rep
PB53620TB	STOCK	

Item	Description	Qty	Total
Chassis	2026 PETERBILT 536 VIN# TBD	1	118,478.00
Bodies	2025 20TB-22' SERIAL #TBD	1	47,245.00
C-NC112	FULLY CONFIGURABLE EQUIPMENT	1	0.00
C-NC19	20 000TB	1	0.00
C-2022	22'-20 000-TB	1	0.00
C-NC46	COMPLETE EQUIPMENT	1	0.00
C-D414	4 CHAIN SLOTS PER SIDE (16 TOTAL FOR 21', 22', 23', 24')	1	0.00
C-D	"3/16" CHECKER PLATE DECK (STANDARD)	1	0.00
C-PGAL-1	DECK GALVANIZED (OPTION FOR 18'-23' DECKS)	1	0.00
C-C1	FLAT TOP DECK, WITH REMOVABLE RAILS	1	0.00
C-B3	3" HIGH X 9" SPACING (OPTION FOR 20 000-TB)	1	0.00
C-L16	5 MARKER LIGHTS PER SIDE	1	0.00
C-T02	RAMSEY HDP 10,000 LBS WITH 7/16" X 75' WIRE ROPE (OPTION FOR 10 000-TB AND 20 000-TB)	1	0.00
C-T15	WINCH AIR FREE SPOOL ON LEFT HAND SIDE	1	0.00
C-NC30	75' WIRE ROPE	1	0.00
C-CR01	SWIVEL HOOK	1	0.00
C-NC24	SINGLE AXLE	1	0.00
C-12V	12V WIRING	1	0.00
C-NC44	MEDIUM DUTY STINGER AND WHEEL LIFT (STANDARD FOR 20 000-TB) (3X3 T-BAR)	1	0.00
C-G20	GALVANIZED SUB-FRAME AND BUMPER	1	0.00
C-NC17	CLEAR MARKER LIGHT	1	0.00
C-L118	8 X 4 1/2" LIGHT (6 RED (STOP-FLASH) / 2 BACKUPS) - ON BUMPER	1	0.00
C-NC11	LEVER CONTROL STANDARDS	1	0.00
C-INCL	WHEEL LIFT SYSTEM (OPTION INCLUDES 3X3 T-BAR)	1	0.00
C-S052	STAINLESS ON REAR BUMPER	1	0.00
C-G011	STABILIZER GRIP (20,000) (3X3)	1	0.00
C-L112-1	2 LED WORK LIGHTS ON TOP OF THE REAR BUMPER	1	0.00
C-B06	HITCH RECEIVER ASSEMBLY 10-20 000LBS (2"X2")	1	0.00
		Total	

156 Epping Rd.
Exeter, NH 03833
(603)778-8158
www.netruckcenter.com

Date	Estimate #
12/10/2024	PB53620TB

Name / Address
New England Truck Center 156 Epping Road Exeter, NH 03833

OP#	PO #	Rep
PB53620TB	STOCK	

Item	Description	Qty	Total
C-A1	STANDARD CHAIN RACK	1	0.00
C-A12	STD WINCH EMBEDDED IN CHAIN RACK	1	0.00
C-L118	8 X 4 1/2" LIGHT (6 RED (STOP-FLASH) / 2 BACKUPS) - ON CHAIN RACK	1	0.00
C-NC40	CHAIN RACK NRC BLACK PAINT	1	0.00
C-S093	STAINLESS ON SIDES AND HEAD OF CHAIN RACK	1	0.00
C-L112-1	2 LED WORK LIGHTS UNDER THE TOP OF THE CHAIN RACK	1	0.00
C-LO2P	WIRELESS REMOTE CONTROL LODAR 2 BUTTONS (WINCH)	1	0.00
C-A421	RECOVERY ROLLER GUIDE (ROLLBACK)	1	0.00
C-S056	STAINLESS ON OIL TANK	1	0.00
C-NC110	WIRED TOWLIGHT ONLY	1	0.00
C-T6	TOUCHPAD WITH FUSELESS LIGHTING SYSTEM CONTROLLER	1	0.00
C-P-O	NO NEW CUSTOM REQUEST	1	0.00
C-DISCLAIMER	CUSTOMER, FINAL PURCHASER OR END USER HAS BEEN INFORMED OF THE RISKS AND BENEFITS OF HOT DIP GALVANIZING (HDG) OF HIS NRC CAR CARRIER DECK	1	0.00
C-NC26	"BLACK POLYMER CONTROL BOXES (STANDARD)	1	0.00
C-RACK5	68" [1727MM] - HEIGHT ABOVE FRAME RAILS [C#5]	1	0.00
DESTTRANSPORT	UNCONFIGURABLE ITEMS		
20TBINSTALL-INST	DESTINATION TRANSPORT CHARGE	1	1,300.00
72AMBJUSTLB-INST	DEALER INSTALL WITH PTO, STANDARD STOCK PAINT AND DETAIL	1	10,500.00
MX601818.K-INST	72" AMBER JUSTICE LIGHT BAR INSTALLED	1	2,450.00
MX481818.KNB-INST	60" RC TOOLBOX ALUMINUM BOX, STAINLESS STEEL DOOR INSTALLED	1	1,626.03
	48" RC TOOLBOX ALUMNIUM BOX, STAINLESS STEEL DOOR INSTALLED	3	3,902.43
		Total	

156 Epping Rd.
Exeter, NH 03833
(603)778-8158
www.netruckcenter.com

Date	Estimate #
12/10/2024	PB53620TB

Name / Address
New England Truck Center 156 Epping Road Exeter, NH 03833

OP#	PO #	Rep
PB53620TB	STOCK	

Item	Description	Qty	Total
	PRICING SUBJECT TO CHANGE, WILL BE FINANLIZED OUT CLOSER TO BUILD TIMELINE.		
		Total	\$185,501.46

ONCE THE BUYER ACCEPTS THIS ORDER, THE BUYER'S DEPOSIT IS NOT REFUNDABLE UNLESS THE BUYER CANNOT TAKE DELIVERY OF SAID VEHICLE(S) FOR A REASON BEYOND THE BUYER'S CONROL. IN THAT EVENT, THE DEALER MAY, BUT WILL NOT BE REQUIRED TO, RETURN THE DEPOSIT TO THE BUYER, LESS ANY EXPENSES WHICH THE DEALER HAS INCURRED IN ACCEPTING AND PROCESSING THIS ORDER. THE BUYER'S FAILURE TO OBTAIN FINANCING BEFORE SCHEDULED DELIVERY IS NOT A REASON BEYOND THE BUYER'S CONTROL. THE BUYER WILL ALSO BE SUBJECT TO ANY PRICE INCREASES THAT ARE RECEIVED BY THE DEALER PERTAINING TO THE CHASSIS OR BODY. BY SIGNING THIS THE BUYER ACKNOWLEDGES HAVING READ AND AGREEING TO THESE TERMS AND CONDITIONS.

Signature _____



Terms & Conditions

- Once the buyer accepts this order, the buyer's deposit is not refundable unless the buyer cannot take delivery of the said vehicle(s) for a reason beyond the buyer's control. In that event, the dealer may, but will not be required to return the deposit to the buyer, less any expenses which the dealer has incurred in accepting and processing this order. The buyer's failure to obtain financing before scheduled delivery is not a reason beyond the buyer's control.
- The buyer will be subject to any price increase and or surcharge that are received by the dealer pertaining to the chassis or body.
- The buyer will be subject to any price increase on raw materials / parts that are incurred from the time of placing the order to the actual time of build and delivery of the unit(s).
- By signing this the buyer acknowledges having read and agreeing to these terms and conditions.

Date: _____

Signature of Purchaser: _____

Opp# _____ Chassis: _____ Body: _____

NETC Representative: _____

"Everything Truck"

156 Epping Road Exeter NH 03833 +1 603 778 8158

www.NEtruckcenter.com