



156 Epping Road Exeter, NH 03833

800-261-7219

Stock Number: #488836

2026 White Peterbilt 567

Details:

- 2024 NRC 40TB - 28'
- Wood Deck and Galv Subframe
- Lodar Remote
- 20k Winch
- Cummins X15
- 525HP
- Allison 4500 RDS-P Gen-6
- Full Chassis / Body spec attached

Price: \$341,705



THE UNIVERSITY OF MASSACHUSETTS
 100 SOUTH GATE STREET
 AMHERST, MASSACHUSETTS 01003

New England Truck Center
156 Epping Road
Exeter, New Hampshire 03833
United States of America

MIKE LAMPERT

Vehicle Summary

	Unit		Chassis
Model:		Model 567	Fr Axle Load (lbs): 20000
Type:		Full Truck	Rr Axle Load (lbs): 40000
Description 1:		STOCK 567 REG	G.C.W. (lbs): 80000
Description 2:			
	Application		Road Conditions:
Intended Serv.:		Wrecker	Class A (Highway) 100
Commodity:		Transportation Equipment	Class B (Hwy/Mtn) 0
			Class C (Off-Hwy) 0
	Body		Class D (Off-Road) 0
Type:		Platform w/Devices	Maximum Grade: 6
Length (ft):		24	Wheelbase (in): 309
Height (ft):		12	Overhang (in): 60
Max Laden Weight (lbs):		5000	Fr Axle to BOC (in): 90.1
			Cab to Axle (in): 218.9
	Trailer		Cab to EOF (in): 278.9
No. of Trailer Axles:		0	Overall Comb. Length (in): 400
Type:			
Length (ft):		0	Special Req.
Height (ft):		0	
Kingpin Inset (in):		0	
Corner Radius (in):		0	
	Restrictions		
Length (ft):		40	
Width (in):		102	
Height (ft):		13.5	

Approved by: _____

Note: All sales are F.O.B. designated plant of manufacture.

Sales Code	Std/Opt	Description	\$ List	Weight
Base Model				
0005671	S	Model 567 The Model 567 is available in both a set-forward and set-back front axle configuration to provide customers with maximum versatility for their application requirements. For weight-sensitive applications, the set-forward front axle provides optimized weight distribution and compliance with bridge laws. The Model 567 has steer axle ratings up to 22,000 lbs. The 567 also offers single, tandem or tridem drive axles and a variety of lift axles for added versatility. Available with a 115" or 121" BBC and as a day cab or with a selection of detachable sleeper configurations, the 567 is as versatile as it is reliable.	207,933	14,800
0091170	O	Transportation Equipment	0	0
0093110	O	Wrecker Truck with recovery body used for recovering and towing stranded vehicles and equipment.	0	0
0095010	O	Platform w/Devices	0	0
0098170	S	United States Registry Canadian Registry Package Requires Air Conditioning Excise Tax Canada, Speedometer to be KPH ipso MPH, Daytime Running Lights and Rubber Battery Pad in Bottom of Battery Box.	0	0
Configuration				
0200700	S	Not Applicable Secondary Manufacturer	0	0
Frame & Equipment				
0514050	O	10-3/4" Steel Rails 385-402" 10.75x3.5x.375 Dimension, 2,136,000 RBM; Yield Strength: 120,000 psi. Section Modulus: 17.8 cubic inches. Weight: 1.74 lbs/inch pair	903	587
0601500	O	Full Steel Inner Liner	1,827	808
0611250	O	Heavy-Duty Iron Front Spring Brackets With Front Air Leaf the front spring bracket is iron but not the shackle bracket	330	35
0611330	O	Zinc Coated Anti Corrosion Treated Frame Rails Requires Frame Rail Code. Zinc Phosphate coating will replace the standard frame rail primer and provide added corrosion prevention for your customer's operating in severe conditions or in climates where vehicle rust is common.	387	4
0611790	S	Aluminum Frame Rail Crossmembers Excludes suspension	0	0
0644090	O	EOF Square without Crossmember End-of-frame square without crossmember. For use with body builder installed crossmember.	57	-64
0651090	O	Omit Rear Mudflaps and Hangers	-58	-25

Price Level: January 1, 2024

Deal: STOCK 567 REG

Printed On: 10/15/2024 12:39:47 PM

Date: October 15, 2024

Quote Number: QUO-1137655-C7Y6T8

Sales Code	Std/Opt	Description	\$ List	Weight
Front Axle & Equipment				
1011890	O	PACCAR FX-20 Steer Axle 20,000 lbs. 4" Drop Axle is designed for applications with a gross axle weight rating (GAWR) of 20,000 pounds. Front axle is designed for demanding applications such as construction, heavy haul, refuse, and other vocational uses. Robust forged steel beam construction for long-lasting performance. It utilizes innovative tapered kingpin roller bearings for more efficient operation and improved steering efficiency. The PACCAR Steer Axle comes standard with the PACCAR warranty of 5 years, 750,000 miles.	2,631	137
1114030	O	Taper Leaf Springs, Shocks 20,000 lb Standard with Heavy Resistance Shocks.	652	119
1243050	O	Power Steering Sheppard HD94 Dual Gear For use with 16,000 to 20,000 lb. axle ratings.	1,604	80
1250250	O	Power Steering Reservoir Frame Mounted w/Cooler A power steering cooler helps reduce the heat of the power steering fluid. This is commonly used with systems that may experience more stress from towing or off-road driving.	213	2
1354850	O	PHP10 Iron PreSet PLUS Hubs - Air Disc Preset iron hub assemblies are designed for demanding conditions and require less maintenance while still offering dependability and superior performance. Precisely engineered to minimize roller stress under heavy loads and increase bearing life when used in demanding conditions such as wide-based single wheels and misalignment due to spindle wear.	170	42
1380070	O	Greasable Front Spring Pins	71	0
1380290	S	Bendix Air Disc Front Brakes Bendix air disc front brakes use a floating caliper design to provide foundation braking on all axles and complies with reduced stopping distance regulations.	0	0
1380380	S	Tenneco Shocks For Steer Axle Integrated front suspension to suit heavy duty truck market, combining the air spring and the damper into one module.	0	0
1380490	O	PACCAR FX Wide Track IPO Standard 71in KPI IPO 69in front axle for improved turning radius.	0	15
Rear Axle & Equipment				
1523310	O	Dana Spicer DSH40 40,000 lb, High Performance 40 Interaxle diff lock air rocker occupies space of one gauge. Laser factory axle alignment to improve handling & reduce tire wear. Magnetic rear axle oil drain plug captures & holds any metal fragments in drive axle lube to extend service life. Parking brakes on all drive axles for optimal performance. Cognis EMGARD® FE 75W-90 synthetic axle lube provides over 1% fuel economy improvement. Reduces wear & extends maintenance intervals, resulting in increased uptime. Provides improved fluid flow to protect components in extreme cold conditions & withstand the stress from high temperatures, extending component life.	500	179

Price Level: January 1, 2024

Deal: STOCK 567 REG

Printed On: 10/15/2024 12:39:47 PM

Date: October 15, 2024

Quote Number: QUO-1137655-C7Y6T8

Sales Code	Std/ Opt	Description	\$ List	Weight
1603146	O	Watson-Chalin SL13 Sif-Strg Pusher 13,500 Lb, Includes (1) Air Tank	11,079	938
1607152	O	52in Pusher Axle Spacing From Centerline of Forward Drive Axle	0	0
1615180	O	PHP10 Iron PreSet PLUS Hubs, Cast Drums With 13.5K or 20K Self-Steering Pusher Axles	-285	0
1616290	S	PHP10 Aluminum PreSet PLUS Hubs	0	0
1660000	O	Dust Shields For Cam Brakes, Drive Axle(s)	83	4
1673090	O	Separate Dash Controls, Cont Trac Full Lock Dana Spicer or Meritor - Tandem or Tri-Drive Axles	118	2
1680450	O	Rear Brake Camshaft Reinforcement Rear brake camshaft reinforcement helps guard against wear and corrosion.	130	9
1680490	O	Gusseted Cam Brackets, Drive Axle(s)	70	2
1680500	O	SBM Valve Full trucks require a spring brake modulation (SBM) system for emergency braking application. This system requires an SBM valve and a relay valve with spring brakes on the rear axles. The SBM valve allows the foot valve to operate the rear axle spring brakes if a failure exists in the rear air system.	285	0
1680950	O	Stability System Not Selected Or Not Available	-101	0
1682710	S	Anti-Lock Braking System (ABS) 6S6M ABS-6. Includes air braking system.	0	0
1683235	O	Omit Tire Pressure Monitoring System	-446	0
1684200	S	Synthetic Axle Lubricant All Axles Peterbilt heavy duty models include Fuel Efficient Cognis EMGARD FE75W-90 which provides customers performance advantages over current synthetic lubricants with reduced gear wear and extended maintenance intervals, resulting in increased uptime. In addition, the lubricant provides improved fluid flow to protect gears in extreme cold conditions and withstand the stress from high temperatures, extending component life.	0	0
1685280	O	Lift Axle Regulator & Gauge LH Driver Seat Lift axle regulator and gauge, left hand driver seat, with switch and gauge in dash.	919	0
1685465	O	Stowed Lifted Axle Lower To Maximize Body Clearance	0	0
1687010	S	Bendix Air Cam Rear Drum Brakes 16.5x7 Bendix Air Cam Rear Drum Brakes to fit all heavy haul, construction, refuse and highway truck and tractor applications. Includes Automatic Slack Adjusters & Outboard Mounted Brake Drums.	0	0
1687090	O	Diff Lock Tandem Axles With Speed Interlock. Automatically Disengages Wheel Diff Lock at Speeds Above 25 mph.	2,005	60

Price Level: January 1, 2024

Deal: STOCK 567 REG

Printed On: 10/15/2024 12:39:47 PM

Date: October 15, 2024

Quote Number: QUO-1137655-C7Y6T8

Sales Code	Std/Opt	Description	\$ List	Weight
1703360	O	Ratio 3.36 Rear Axle	0	0
1821970	O	Peterbilt Low Air Leaf 40,000 lb, 52in Axle Spacing, Light Weight	707	-59
1922260	O	Dash Mtd Dump Switch with Indicator Light Dash mounted dump switch with indicator light for suspension.	59	2

Engine & Equipment

2059212	O	X15 525@1900 GOV@1900 1850@1000 Performance Series (2024 Emissions)	13,759	465
		N21350 C121 64....Maximum Accelerator Vehicle		
		N21370 C128 64....Maximum Cruise Control Speed		
		N21460 C132 1400..PTO Maximum Engine Speed		
		N21520 C133 5.....Idle Shutdown Timer		
		N21610 C188 39....Idle Shutdown Cold Ambient A		
		N21620 C189 60....Idle Shutdown Intermediate A		
		N21630 C190 80....Idle Shutdown Hot Ambient Ai		
		N21550 C206 35....Idle Shutdown Percent Engine		
		N21340 C209 120...Maximum Vehicle Speed		
		N21510 C225 YES...Idle Shutdown with Parking B		
		N21450 C231 NO....Gear Down Protection		
		N21570 C233 NO....Idle Shutdown Manual Override		
		N21440 C234 NO....Engine Protection Shutdown		
		N21480 C238 NO....Cruise Control and Engine Br		
		N21470 C239 NO....Cruise Control Auto-Resume		
		N21430 C333 0.....Driver Initiated OverrideMax		
		N21410 C334 0.....Driver Initiated Override Ma		
		N21590 C382 YES...Idle Shutdown Hot Ambient Au		
		N21500 C395 0.....Green House Gas Automatic En		
		N21530 C396 YES...Idle Shutdown Warning Period		
		N21540 C397 60....Idle Shutdown Warning Period		
		N21320 C399 120...Green House Gas Vehicle Spee		
		N21400 C400 252...Driver Initiated Override Re		
		N21420 C401 10....Green House Gas Vehicle Spee		
		N21330 C402 0.....Green House Gas Vehicle Spee		
2091120	S	EMUX Electronics Architecture	0	0
2091305	S	Engine Idle Shutdown Timer Enabled	0	0
2091315	O	Enable EIST Ambient Temp Overrule	0	0
2091372		Eff EIST NA Expiration Miles	0	0
2091640		Effective VSL Setting NA	0	0
2092017	O	Typical Operating Speed 68 MPH	0	0
2092033	O	Powertrain Optimized for Balance	0	0

Price Level: January 1, 2024

Deal: STOCK 567 REG

Printed On: 10/15/2024 12:39:47 PM

Date: October 15, 2024

Quote Number: QUO-1137655-C7Y6T8

Sales Code	Std/ Opt	Description	\$ List	Weight
		Best analysis for vehicles where service includes frequent start and stop cycles.		
2140200	O	CARB Engine Idling Compliance PACCAR PX-7, PX-9 and MX, Cummins X15 and ISX diesel engines will include the required factory installed serialized sticker on the drivers door to identify them as meeting the NOx idling standard.	0	0
2140410	S	Engine Brake Controls Located on RH Column	0	0
2140450	O	Remote PTO/Throttle, 12-Pin Eng Bay Remote Control Provision	165	0
2140660	O	CARB Emission Warranty	0	0
2140700	S	EPA Engine Idling Compliance	0	0
2513060	S	PACCAR 160 Amp Alternator, Brushed PACCAR 160 AMP alternator, brushed producing 160 Amps at road speed and 100 Amps at idle.	0	0
2521090	S	Immersion Type Block Heater 110-120V Standard location is left-hand under cab, Model 520 is in bumper, and for Model 220 it is at the driver step. Plug includes a weather-proof cover that protects the receptacle. This pre-heater keeps the coolant in the engine block from freezing when the engine is not running.	0	0
2522090	O	PACCAR Premium Starter - X15 Engines Only PACCAR Premium 12 volt. Better cranking power, lower current draw and improved warranty to 36 months / 350,000 mi / 560,000 km.	464	0
2538040	S	3 PACCAR Premium 12V Dual Purpose Batt 2190 CCA Threaded stud type terminal. Stranded copper battery cables are double aught (00) or larger to reduce resistance.	0	0
2539720	S	Low Voltage Disconnect System	0	0
2621000	O	2-Speed Fan Clutch For Frequent Start/Stops A 2-speed fan clutch is ideal for vocational applications where the fan clutch engagement time exceeds 10% of the engine run time. When the fan clutch is disengaged, the fan still rotates at 15-25% of the engine RPM. This fan rotation provides crucial airflow to the engine and draws virtually no horsepower.	537	0
2723220	O	18.7 CFM Naturally Aspirated Air Compressor X15 Only	0	0
2812170	O	Intebrake (Furnished on Engine) Features a dedicated cam lobe design for optimum power and three-stage engine brake operation.	0	0
2921120	O	PACCAR Fuel/Water Separator Extended Service Interval	239	0
2921220	O	Fuel Heat for Fuel Filter	54	0
2921320	O	12V Heat for Fuel Filter Fuel filter heaters help ensure a seamless flow of diesel from the tank to the combustion chamber. Eliminating any possibility of moisture freezing within the fuel filter while simultaneously increasing the fuel temperature for atomization within the engine.	66	0

Price Level: January 1, 2024

Deal: STOCK 567 REG

Printed On: 10/15/2024 12:39:47 PM

Date: October 15, 2024

Quote Number: QUO-1137655-C7Y6T8

Sales Code	Std/ Opt	Description	\$ List	Weight
3114270	S	High Efficiency Cooling System Cooling module is a combination of steel and aluminum components, with aluminum connections to maximize performance and cooling capability. Silicone radiator & heater hoses enhance value, durability, & reliability. Constant tension band clamps reduce leaks. Chevron Delo Extended Life Coolant (NOAT) extends maintenance intervals reducing maintenance costs. Anti-freeze effective to -30 degrees F helps protect the engine. Low coolant level sensor warns of low coolant condition to prevent engine damage. Radiator Size by Model: 520 1202 sq in, 579 1456.9 sq in, 535/536/537/548 949.3 sq in, 537/548 VOC 1000.3 sq in, 389 HH 1604 sq in, 567 1379 sq in.	0	0
3291680	S	(1) Air Cleaner Firewall Mounted Molded rubber air intake connections with lined stainless steel clamps seal to prevent contaminants in air intake.	0	0
3367240	O	Exhaust Dual SOC, LH SOC Stack Aesthetic Only, DPF/SCR RH Under Cab, Single Module	2,693	85
3381790	O	Chrome Finish Over Elbows for Dual Exhaust Requires DPF tool box right-hand under cab, and battery box left-hand under cab.	622	13
3387870	S	24" Ht, 5" Dia Chrome, Clear Coat Standpipe(s)	0	0
3387880	O	7" Dia Chrome Plated Steel Standpipe(s) IPO 5"	242	4

Transmission & Equipment

4052970	O	Allison 4500 RDS-P Transmission, Gen 6 Rugged Duty Series	24,013	528
4210870	O	RPL20 Driveline Interaxle Requires RPL20 Driveline interaxle (option 4210870) for tandem rear axles. RPL20 series drivelines are built for heavy-duty commercial vehicles and are permanently lubricated and sealed for life with triple lip seals to protect against contaminants. All Meritor drivelines will be primed before painted, improving paint adhesion for longer lasting quality in the field.	0	0
4211250	O	RPL25 Driveline, 2 Midship Bearings Requires RPL20 Driveline interaxle (option 4210870) for tandem rear axles. Provides a driveline that is permanently sealed and lubricated. All Meritor drivelines will be primed before painted, improving paint adhesion for longer lasting quality in the field.	1,664	210
4233910	O	(1) Dash Mounted Single Acting EOH PTO Control Electric-over-hydraulic, spec'ing PTO switch does not ensure the PTO will fit. Sends signal to Allison to engage PTO.	106	0
4250660	U	TC-571 Torque Converter	0	0
4252170	O	Auto Neutral Activates With Parking Brake Auto Neutral helps improve jobsite safety by reducing the possibility of the truck moving due to throttle application.	21	0
4252890	O	Allison FuelSense Not Desired Dynamic Shift Sensing	0	0
4252940	O	Allison Neutral At Stop	0	0

Price Level: January 1, 2024

Deal: STOCK 567 REG

Printed On: 10/15/2024 12:39:47 PM

Date: October 15, 2024

Quote Number: QUO-1137655-C7Y6T8

Sales Code	Std/ Opt	Description	\$ List	Weight
		Neutral at Stop features and benefits: Reduces or eliminates the load on the engine when vehicle is stopped, can help lower fuel consumption and CO2 emissions, and is included in FuelSense 2.0 Plus and Max packages only.		
4256740	O	Allison 6-Speed Configuration, Wide Ratio Gears Allison 4500 transmission only	0	0
4256920	O	Dash Mounted Push Button Shifter Available with Allison transmissions	148	0
Air & Trailer Equipment				
4510210	O	Bendix AD-HF EP Air Dryer, Heater Coalescing filter, extended purge. Bendix AD-HF air filters protects the life of your engine system and components. Proven PuraGuard oil coalescing technology in the air dryer cartridge. This oil coalescing filter ensures the removal of oil and oil aerosols before they can contaminate the moisture removing desiccant.	160	6
4520420	O	Pull Cords All Air Tanks	4	1
4540260	O	Dash Winch Brake Switch To Operate All Brakes (Truck & Trailer). A&E EOF On Moveable Xmbr.	370	17
4540420	S	Nylon Chassis Hose	0	0
4543320	S	Steel Painted Air Tanks All air tanks are steel with painted finish except when Code 4543330 Polish Aluminum Air Tanks is also selected (then exposed air tanks outside the frame rails will be polished aluminum). Peterbilt will determine the optimal size and location of required air tanks. Narratives requesting a specific air tank size or location will not be accepted for factory installation. See ECAT to determine number or location of air tanks installed.	0	0
4543330	O	Polished Aluminum Air Tanks Outside Frame Rails Exposed air tanks outside the frame rails will be polished aluminum. Air tanks mounted inside the frame rails or covered by other components will be either painted aluminum (4543340) or painted steel (4543320) air tanks depending on air tank option selected.	244	0
4610920	S	Self-Returning Brake Hand Valve Dash mounted controls	0	0
4611930	O	Body Connections 5' BOC Junction box contains light and power circuits for body connections located 5' from back-of-cab	194	6
Tires & Wheels				
5058970	O	FF: MN 20ply 315/80R22.5 XZUS2 Efficiency Rating: Fair All-position, wide base single designed for significant weight and fuel savings in urban regional applications. Diameter = 42.9 inches; SLR = 19.8 inches. Compares to Goodyear G289 WHA and Bridgestone M860 tread.	953	98
5156160	O	RR: MN 18ply 295/60R22.5 X Multi D	1,844	8

Price Level: January 1, 2024

Deal: STOCK 567 REG

Printed On: 10/15/2024 12:39:47 PM

Date: October 15, 2024

Quote Number: QUO-1137655-C7Y6T8

Sales Code	Std/ Opt	Description	\$ List	Weight
		Efficiency Rating: Fair		
5190008	S	Code-rear Tire Qty 08	0	0
5220520	O	FF: Alcoa 89U637 22.5 X 9.00 High Polish Aluminum, Ultra ONE technology that saves more than 50 lbs. versus a comparable steel wheel. Built for refuse, logging, mining and other heavy haul applications that demand a tough wheel. Each wheel offers a 10,000 lbs. load rating.	506	-36
5320530	O	RR: Alcoa 89U647 22.5X9.00 High Polish Aluminum. Ultra ONE wheels with MagnaForce alloy.	1,972	-80
5390008	S	Code-rear Rim Qty 08	0	0
5407640	O	FF: Mirror Polish Wheels, Outer Surface Single/tandem steer. Mirror Polish outer surface of outer wheel. Without chrome wheel nuts.	73	0
5407660	O	RR: Mirror Polish Wheels, Outer Surface, Tandem Drive Mirror polish outer surface of outer wheels (4). Without chrome wheel nuts.	566	0
5407700	O	PR: Mirror Polish Wheels, Outer Surface All pusher axles. Mirror polish outer surface of outer wheel.	283	0
5410140	O	FF: Dura-Bright Finish Outer Surface of Outer Wheel, requires Polished Option	262	0
5410160	O	RR: Dura-Bright Finish-Tandem Axle Outer Surface of Outer Wheel, requires Polished Option	524	0
5410200	O	PR: Dura-Bright Finish All pusher axles - outer surface of outer wheel, requires polished option.	262	0
5475498	O	PR: (2) MN 18ply 295/60R22.5 X Line Energy Z ETRTO; (1) self-steering pusher axle.	1,762	214
5482052	O	PR: (2) Alcoa 89U637 22.5X9.00 High Polish Aluminum, (1) self-steering pusher axle. Ultra ONE technology.	865	98
Fuel Tanks				
5554220	O	26" Aluminum 110 Gallon Fuel Tank LH U/C Includes steps for cab access. Paddle handle filler cap with threadless filler neck. Top draw fuel plumbing reduces chance of introducing air into the fuel system during low fuel level conditions due to the central placement of fuel pickup tube. Wire braid fuel lines increase durability & reduce potential for leaks.	692	24
5602110	O	Location LH U/C 110 Gallon	0	0
5650540	O	Polish (1) Non-Slip Fuel Tank Step, U/C Tank Only	29	0
5650810	O	Polish (1) Aluminum Fuel Tank	261	0
5652830	O	Polish All Fuel / Hydraulic Tank Straps Does not apply to rectangular DEF tank straps	83	0
5652890	S	DEF Tank Mounted LH BOC Models 220 and 520 mounted left hand back-of-cab.	0	0

Price Level: January 1, 2024

Deal: STOCK 567 REG

Printed On: 10/15/2024 12:39:47 PM

Date: October 15, 2024

Quote Number: QUO-1137655-C7Y6T8

Sales Code	Std/ Opt	Description	\$ List	Weight
5652980	S	DEF To Fuel Ratio Between 1:1 And 2:1	0	0
5653000	O	Polished Stainless Steel Cover For DEF Tank	275	0
5655019	S	DEF Tank Small, HD 14 Gal 2.1M MD 5.5 Gal	0	0
5760010	O	RH Tank None Furnished	-712	-86
Battery Box & Bumper				
6010780	O	Aluminum Space Saver Battery Box RH BOC Battery access from side	-341	-60
6030540	O	Polish Battery/Tool Box(s) Aftertreatment Cab Entry, complete	288	0
6040550	S	Aftertreatment Aluminum Non-Slip Cab Entry Aftertreatment right-hand under cab step. DPF/SCR for diesel engines, catalyst for natural gas engines. On Models 579 specifying chassis fairings, the box is aerodynamic.	0	0
6122910	O	Steel Texas Style Bumper Chromed Two tow points.	1,023	-6
Cab & Equipment				
6515770	O	Vocational 121 BBC Alum Cab and Metton Hood SFFA Stainless steel crown and grille with tilt assist.	3,931	-30
6540660	O	SmartSound Cab Insulation Package Cab acoustic insulation package for day cabs. Includes insulated inside firewall, top side floor damping, absorber treated kick panels, and insulated backwall and roof structure.	414	0
6700000	S	No Sleeper Selected	0	0
6800510	O	Fender Lips 2.25" Wide	786	6
6911740	O	Peterbilt LX Driver Peterbilt LX Air seat, high height backrest, adjustable seat track length, 2 chamber lumbar support, premium suspension with adjustable damping, auto leveling, exit air dump, memory for sitting height, fore-aft isolator with lockout, vinyl bellows over suspension, Requires folding armrests, side and back storage pocket. Adds 40mm of increased space for steering wheel to chest and improved driver ingress/egress into cab and sleeper (knee sweep) with improved passenger side ingress/egress for personal carog/luggage. Standard with fabric/vinyl finish - color coordinated with interior color	210	3
6921130	O	Peterbilt LX Passenger seat Peterbilt LX Air seat, high height backrest, adjustable seat track length, 2 chamber lumbar support, premium suspension with adjustable damping, auto leveling, exit air dump, memory for sitting height, fore-aft isolator with lockout and vinyl bellows over suspension. Adds 40mm of increased space for steering wheel to chest and improved driver ingress/egress into cab and sleeper (knee sweep) with improved	646	28

Price Level: January 1, 2024

Deal: STOCK 567 REG

Printed On: 10/15/2024 12:39:47 PM

Date: October 15, 2024

Quote Number: QUO-1137655-C7Y6T8

Sales Code	Std/Opt	Description	\$ List	Weight
		passenger side ingress/egress for personal cargo/luggage. Standard with fabric / vinyl - color coordinated with interior color.		
6930580	O	Drivers Armrests - LH & RH	170	4
6930590	O	Passenger Armrest - LH only Required with Evolution LX seats, optional with Evolution ST Seats.	125	2
6930800	O	Black Seat Color IPO Standard Color	0	0
6939400	S	Air Ride Driver	0	0
6939420	S	High Back Driver	0	0
6939450	O	Leather Driver	320	0
6939500	O	Air Ride Passenger	0	0
6939520	S	High Back Passenger	0	0
6939550	O	Leather Passenger	320	0
7000025	S	Steering Wheel With Multi-Function Includes Peterbilt logo on horn button , audio volume, seek, mute and mode button on LH pod with cruise control on/off/cancel, set/resume and accelerate/coast on the right pod.	0	0
7001520	S	Adjustable Steering Column - Tilt/Telescope	0	0
7037130	S	Prestige Interior - Sterling Gray Features single tone dash with tough, scratch resistant materials including soft touch points on top of dash. Top of dash, door panel uppers, and kick panel are charcoal to conceal dirt and mitigate wear. Includes unique technical grained A,B, C & D instrument panels with contoured doorpads, padded fabric headliner and vinyl wall panels. Superior ergonomics are achieved while maximizing productivity featuring: multiple power ports, (2) coat hooks, header-mounted domelight, power lift driver and passenger windows, LH and RH door mounted map pockets with built-in courtesy lights, driver and passenger dome/reading lights and footwell lighting. Comfort features include automatic temperature HVAC controls, 18 inch 4-spoke soft-touch steering wheel, soft-touch steering column cover, rubber flooring, (3) inside sunvisors, integrated "dead pedal, cup holder and map bin in dash.	0	0
7210420	O	Dark Window Tint IPO Standard Tint - Day Cab	30	0
7210540	S	Day Cab Rear Window Day cab rear window flush to back of cab.	0	0
7210550	S	1-Piece Glass Rear Cab Window Fixed	0	0
7230060	S	1-Piece Curved Windshield	0	0

Price Level: January 1, 2024
Deal: STOCK 567 REG
Printed On: 10/15/2024 12:39:47 PM

Date: October 15, 2024
Quote Number: QUO-1137655-C7Y6T8

Sales Code	Std/ Opt	Description	\$ List	Weight
7230360	S	Power Door Locks and Power Window Lifts Standard	0	0
7322010	S	Combo Fresh Air Heater/Air Conditioner With radiator mounted condenser, dedicated side window defrosters, Bi-Level Heater/Defroster Controls, 54,500 BTU/HR, and silicone heater hoses.	0	0
7410040	O	Outside Sunvisor - Stainless Steel Not available with 2.1M high roof sleeper.	978	0
7510060	O	Aero Rear View Mirror Housing, Bright Finish	330	3
7514010	O	Peterbilt Aero Rear View Mirror, Motorized Includes top mirror with motorized, adjustable dual axis heated glass. Bottom mirror is an integrated convex surface. Includes black textured arms with breakaway feature.	314	3
7514050	S	Look Down Mirror Over Passenger Door with Black Housing	0	0
7610500	S	Air Horn Mounted Under Cab	0	0
7722120	O	ConcertClass, AM/FM, Weatherband, 3.5 Aux	415	10
7725740	O	Midlevel Speaker Package For Cab (4) Speakers	109	6
7728030	O	Radio Mute When In Reverse For automatic or automated transmission	0	0
7728040	O	Bluetooth Phone and Audio Requires USB Port	56	0
7728050	O	USB Port	56	0
7740130	O	Cobra 29 CB Radio Mounted Center Of Header With weatherband. Mounted in center of header, sound tracker & illuminated panel. Includes wiring, microphone clip, & speaker. Must select antenna(s) option.	366	11
7748150	O	(1) Antenna for Factory Installed or F/O CB Mounted LH cowl, low mount only, with antenna cable. Provides clear top of cab.	110	1
7788335	O	Global Telematics Hardware	0	0
7788345	O	Telematics HW Instl But SmartLINQ Dsbld	0	0
7851480	S	Peterbilt Electric Windshield Wipers With Intermittent Feature.	0	0
7852020	O	Cab Air Suspension	250	0
7852050	O	Auto Reset Circuit Protection Daycab and Sleeper	19	0
7900040	O	Fire Extinguisher, Ship Loose Hazmat approved UL listed/rated ABC.	55	7
7900090	O	Triangle Reflector Kit, Ship Loose	36	13

Price Level: January 1, 2024

Deal: STOCK 567 REG

Printed On: 10/15/2024 12:39:47 PM

Date: October 15, 2024

Quote Number: QUO-1137655-C7Y6T8

Sales Code	Std/Opt	Description	\$ List	Weight
		Florescent triangle emergency road flares are designed to meet and exceed all DOT standards.		
7901130	O	Backup Alarm (107 DB)	137	3
8011410	O	Drive Axle #1 Front Oil Temperature Gauge 52mm round, backlit. Physical gauges must be ordered in pairs and are limited to a total of 6. If this option is selected on a truck with VMUX electrical architecture, the gauge will be included in the digital display.	148	0
8011420	O	Drive Axle #2 Rear Oil Temperature Gauge 52mm round, backlit. Physical gauges must be ordered in pairs and are limited to a total of 6. If this option is selected on a truck with VMUX electrical architecture, the gauge will be included in the digital display.	175	0
8011470	O	Engine Oil Temperature Gauge 52mm round, backlit. These physical gauges must be ordered in pairs and are limited to a total of 6. If this option is selected on a truck with VMUX electrical architecture, the gauge will be included in the digital display.	57	0
8011850	O	Transmission Oil Temperature (Main) Located in Digital Cluster Display.	28	0
8021530	O	Air Suspension Pressure 1 Gauge 52mm round, backlit. Physical gauges must be ordered in pairs and are limited to a total of 6.	117	0
8021800	S	Air Filter Restriction Pressure Gauge Located in Digital Cluster Display	0	0
8021810	S	Brake Application Air Pressure (Tractor) Located in Digital Cluster Display.	0	0
8070000	O	Disable Brake Light With Engine Brake	0	0
8070110	O	(5) Additional Dash Switches with Wiring Located on dash panel C. Availability subject to dash space. Includes 4" 14 gauge wire with butt splice at rear of each additional switch.	211	2
8070450	O	Engine PTO Hourmeter Gauge Located In Digital Cluster Display	0	0
8070820	S	Engine Percent Torque Located in Digital Cluster Display	0	0
8070830	O	Main Instrumentation Panel Digital Cluster 15" Display includes: Speedometer, Tachometer, Primary Air Pressure, Secondary Air Pressure, Fuel Level, DEF Level, DPF Filter Status, Fuel Economy, Oil Pressure, Coolant Temp, and Voltmeter.	0	0
8071900	O	Manifold Pressure Gauge 52mm Round, backlit. Physical gauges must be ordered in pairs and are limited to a total of 6. If this option is selected on a truck with VMUX electrical architecture, the gauge will be included in the digital display.	51	2
8076010	O	Pusher Axle Pressure 1 52mm Round, backlit. These physical gauges must be ordered in pairs and are limited to a total of 6.	120	0
8110070	S	Headlights Projector Module Pod Fender mounted turn signals, projector module low beam, complex reflector high beam, pod mounted	0	0

Price Level: January 1, 2024

Deal: STOCK 567 REG

Printed On: 10/15/2024 12:39:47 PM

Date: October 15, 2024

Quote Number: QUO-1137655-C7Y6T8

Sales Code	Std/Opt	Description	\$ List	Weight
8120990	S	(5) Marker Lights, Aero LED On roof, visor, or fairing	0	0
8133470	O	Switch & Wiring for F/O Beacon/Strobe Switch and wiring for furnished by owner beacon / strobe, 10' coiled wire back-of-cab / back-of-sleeper, at rear sill.	52	2
8133900	O	None Furnished Stop/Tail/Backup Lights Available with full truck only, not available with tractor	-46	-7
8134160	O	Self-Canceling Turn Signal	0	0
Paint				
8500710	S	Standard Paint Color Selection	-200	0
8530770	S	(1) Color Axalta Two Stage - Cab/Hood Base Coat/Clear Coat N85020 A - L0006EY WHITE N85500 CAB ROOF L0006EY WHITE N85300 FENDER L0006EY WHITE N85200 FRAME L0001EA BLACK N85400 HOOD TOP L0006EY WHITE	0	0
Shipping Destination				
Options Not Subject To Discount				
9400090	S	Peterbilt Class 8 Standard Coverage 1 year/100,000 Miles (160,000 km)	0	0
9407147	O	Fuel Price Index Factor \$21 NET	21	0
9408558	O	Prognostic Connection Fee	100	0
9408707	O	Base Warr: Emissions (CARB Operation) 5YR/350K MI - X15 PER/PRO Engine	3,495	0
Miscellaneous				
9409001	S	Day Cab / Prestige Interior (DM)	0	0
9409079	O	State Of Registry: New Hampshire	0	0
9409749	O	2024 Series Emissions Engine	0	0
Promotions				

<i>Sales Code</i>	<i>Std/ Opt</i>	<i>Description</i>	<i>\$ List</i>	<i>Weight</i>
-------------------	-----------------	--------------------	----------------	---------------

Special Requirements

- Special Requirement 1 0098170
- Special Requirement 2
- Special Requirement 3
- Special Requirement 4

Order Comments

Total List Price (W/O Freight & Warranty & Surcharges)	\$299,974
Marketing and Service Support Fee	\$1,495
Prepaid Freight	\$3,525
Total Surcharge/Options Not Subject To Discount	\$3,616
Total Weight (lbs)	19,256

Prices and Specifications Subject to Change Without Notice.

Unpublished options may require review/approval.

Dimensional and performance data for unpublished options may vary from that displayed in CRM.

PRICING DISCLAIMER

While we make every effort to maintain the web site to preserve pricing accuracy, prices are subject to change without notice. Although the information in this price list is presented in good faith and believed to be correct at the time of printing, we make no representations or warranties as to the completeness or accuracy of this information. We reserve the right to change, delete or otherwise modify the pricing information which is represented herein without any prior notice. We carefully check pricing specifications, but occasionally errors can occur, therefore we reserve the right to change such prices without notice. We disclaim all liability for any errors or omissions in the materials. In no event will we be responsible for any damages of any nature whatsoever from the reliance upon information from these materials. Please check your order prebills to confirm your pricing information

Shipping Destinations

Intermediate Destination: NONE

Final Destinations	Quantity
--------------------	----------

HORIZONTAL DIMENSIONS

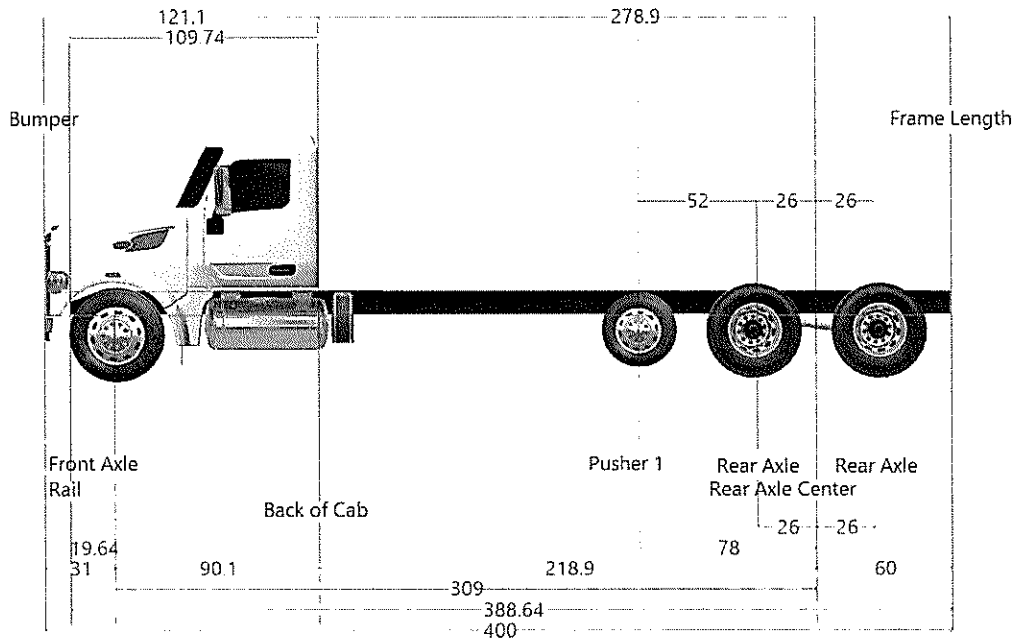

Dimension	Measurement	Start	End
Axle Spacing	52	283	335
Bumper to Back of Cab	121.1	-31	90.1
Bumper to Front Axle	31	-31	0
Bumper to Front Frame	11.36	-31	-19.64
Cab to End of Frame	278.9	90.1	369
Cab to Rear Axle	218.9	90.1	309
Effective Bumper to Back Of Cab	121.1	-31	90.1
Frame Length	388.64	-19.64	369
Front Axle to Back of Cab	90.1	0	90.1
Front of Frame to Axle	19.64	-19.64	0
Load Space	278.9	90.1	369
Overall Length	400	-31	369
Overhang	60	309	369
Pusher Offset #1	-26	283	309
Pusher Offset #2	0	283	309
Pusher Offset #3	0	283	309
Tag Offset	0	309	335
Wheelbase	309	0	309

FRAME LAYOUT

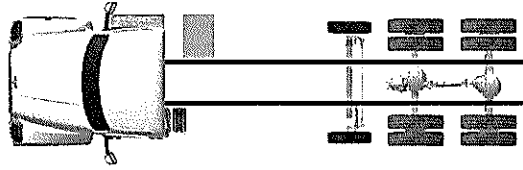

Note: The image displayed is representative only. It should not be construed as a layout diagram. Dimensions and components are not to scale.

Selected Options (Wheelbase: 309)

Sales Code	Description	Length	Side
6040550	Aftertreatment Aluminum Non-Slip Cab Entry	45.3	Right
5655019	DEF Tank Small, HD 14 Gal 2.1M MD 5.5 Gal	7	Left
5554220	26" Aluminum 110 Gallon Fuel Tank LH U/C	55.15	Left
6010780	Aluminum Space Saver Battery Box RH BOC	25.1	Right

156 Epping Rd.
Exeter, NH 03833
(603)778-8158
www.netruckcenter.com

Date	Estimate #
2/5/2025	488836

Name / Address
New England Truck Center 156 Epping Road Exeter, NH 03833

OP#	PO #	Rep
488836	STOCK	

Item	Description	Qty	Total
Chassis	2026 WHITE PETERBILT 567 VIN# 782211 FET INCLUDED	1	233,573.00
40-1586	2024 NRC 40TB-28' SERIAL# 40-1586	1	77,260.00
FET Payable	BODY FET	1	11,446.38
C-NC21	40 000 TB	1	0.00
C-4028	28' - 40 000 TB	1	0.00
C-NC46	COMPLETE EQUIPMENT	1	0.00
C-D415	5 CHAIN SLOTS PER SIDE (18 TOTAL FOR 25', 26', 27', 28', 29', 30')	1	0.00
C-D44-4	SINGLE ROW OF (4) EXTRA CHAIN SLOTS IN THE CENTER OF DECK	1	0.00
C-D6	WOODEN FLOOR (24' TO 30')	1	0.00
C-C3	FLAT TOP DECK WITH STAKE POCKET, WITHOUT REMOVABLE RAILS	1	0.00
C-L16	5 MARKER LIGHTS PER SIDE	1	0.00
C-T04-1	DP 20,000 LBS WITH 5/8" X 75' WIRE ROPE(STANDARD FOR 40 000-TB)	1	0.00
C-NC156	WINCH AIR FREE SPOOL ON LEFT HAND SIDE (NC)	1	0.00
C-NC30	75' STEEL WIRE ROPE	1	0.00
C-CR01	SWIVEL HOOK	1	0.00
C-CTR01	EXTRA FOR TRI-AXLE BODY	1	0.00
C-12V	12V WIRING	1	0.00
C-E51	HEAVY DUTY TOW BAR T-BAR 4" X 4" (STD)	1	0.00
C-G20	GALVANIZED SUB-FRAME AND BUMPER	1	0.00
C-NC17	CLEAR MARKER LIGHT	1	0.00
C-L118	8 X 4 1/2" LIGHT (6 RED (STOP-FLASH) / 2 BACKUPS) - ON BUMPER	1	0.00
C-NC11	LEVER CONTROL STANDARDS	1	0.00
C-S052	STAINLESS ON REAR BUMPER	1	0.00
C-G012	STABILIZER GRIP (30,000 & 40,000 LBS) (4X4)	1	0.00
C-L112-1	2 LED WORK LIGHTS ON TOP OF THE REAR BUMPER	1	0.00
		Total	

156 Epping Rd.
Exeter, NH 03833
(603)778-8158
www.netruckcenter.com

Date	Estimate #
2/5/2025	488836

Name / Address
New England Truck Center 156 Epping Road Exeter, NH 03833

OP#	PO #	Rep
488836	STOCK	

Item	Description	Qty	Total
C-A432	TRAILER HITCH & PINTLE HOOK ADAPTOR (4 HOLES) (T-BAR 4X4)	1	0.00
C-A1	STANDARD CHAIN RACK	1	0.00
C-A12	STD WINCH EMBEDDED IN CHAIN RACK	1	0.00
C-L118	8 X 4 1/2" LIGHT (6 RED (STOP-FLASH) / 2 BACKUPS) - ON CHAIN RACK	1	0.00
C-NC40	CHAIN RACK NRC BLACK PAINT	1	0.00
C-S093	STAINLESS ON SIDES AND HEAD OF CHAIN RACK	1	0.00
C-L112-1	2 LED WORK LIGHTS UNDER THE TOP OF THE CHAIN RACK	1	0.00
C-LO6P	WIRELESS REMOTE CONTROL LODAR 6 BUTTONS	1	0.00
C-A421	RECOVERY ROLLER GUIDE (ROLLBACK)	1	0.00
C-S056	STAINLESS ON OIL TANK	1	0.00
C-NC110	WIRED TOWLIGHT ONLY	1	0.00
C-T6	TOUCHPAD WITH FUSELESS LIGHTING SYSTEM CONTROLLER	1	0.00
C-P-O	NO NEW CUSTOM REQUEST	1	0.00
C-PGAL-2	DECK GALVANIZED (OPTION FOR 24'-30' DECKS)	1	0.00
C-DISCLAIMER	CUSTOMER, FINAL PURCHASER OR END USER HAS BEEN INFORMED OF THE RISKS AND BENEFITS OF HOT DIP GALVANIZING (HDG) OF HIS NRC CAR CARRIER DECK	1	0.00
C-NC26	"BLACK POLYMER CONTROL BOXES (STANDARD)	1	0.00
C-RACK6	74" (1880MM) - HEIGHT ABOVE FRAME RAILS (C#6) UNCONFIGURABLE ITEMS	1	0.00
DESTTRANSPORT	DESTINATION TRANSPORT CHARGE	1	1,300.00
30/40TBINSTALL-IN...	DEALER INSTALL WITH PTO, HOSE TRACK, STANDARD STOCK PAINT AND DETAIL	1	11,500.00
72AMBJUSTLB-INST	72" AMBER JUSTICE LIGHT BAR INSTALLED	1	2,450.00
MX701818.KM-INST	70" RC TOOLBOX, ALUMINIUM BOX, STAINLESS STEEL DOOR INSTALLED	2	4,176.52
Total			\$341,705.90

ONCE THE BUYER ACCEPTS THIS ORDER, THE BUYER'S DEPOSIT IS NOT REFUNDABLE UNLESS THE BUYER CANNOT TAKE DELIVERY OF SAID VEHICLE(S) FOR A REASON BEYOND THE BUYER'S CONTROL. IN THAT EVENT, THE DEALER MAY, BUT WILL NOT BE REQUIRED TO, RETURN THE DEPOSIT TO THE BUYER, LESS ANY EXPENSES WHICH THE DEALER HAS INCURRED IN ACCEPTING AND PROCESSING THIS ORDER. THE BUYER'S FAILURE TO OBTAIN FINANCING BEFORE SCHEDULED DELIVERY IS NOT A REASON BEYOND THE BUYER'S CONTROL. THE BUYER WILL ALSO BE SUBJECT TO ANY PRICE INCREASES THAT ARE RECEIVED BY THE DEALER PERTAINING TO THE CHASSIS OR BODY. BY SIGNING THIS THE BUYER ACKNOWLEDGES HAVING READ AND AGREEING TO THESE TERMS AND CONDITIONS.

Signature _____



Terms & Conditions

- Once the buyer accepts this order, the buyer's deposit is not refundable unless the buyer cannot take delivery of the said vehicle(s) for a reason beyond the buyer's control. In that event, the dealer may, but will not be required to return the deposit to the buyer, less any expenses which the dealer has incurred in accepting and processing this order. The buyer's failure to obtain financing before scheduled delivery is not a reason beyond the buyer's control.
- The buyer will be subject to any price increase and or surcharge that are received by the dealer pertaining to the chassis or body.
- The buyer will be subject to any price increase on raw materials / parts that are incurred from the time of placing the order to the actual time of build and delivery of the unit(s).
- By signing this the buyer acknowledges having read and agreeing to these terms and conditions.

Date: _____

Signature of Purchaser: _____

Opp# _____ Chassis: _____ Body: _____

NETC Representative: _____

"Everything Truck"

156 Epping Road Exeter NH 03833 +1 603 778 8158

www.NEtruckcenter.com